

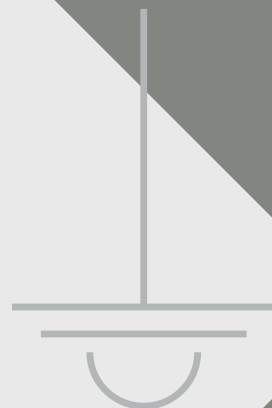

Quadrifoglio Group

Lighting & Acoustic Collection



Quadrifoglio Group. Living and breathing design, everywhere

We are Ethics and Vision in the form of Order and Ergonomics.

Design Office, Living and Lighting. Three ways of exploring design, united by the quality of the materials, the quest for elaborate finishes and the continuous focus on comfort and well-being, as part of an all-Italian identity.

Quadrifoglio Group, vivere il design, ovunque

Siamo Etica e Visione declinate in Ordine ed Ergonomia.

Design Office, Living e Lighting. Tre modi di coniugare il design, accomunati dalla qualità dei materiali, dalla ricerca di finiture elaborate e dalla tensione continua al comfort e al benessere, nel segno di un'identità tutta italiana.



Our Identity

Strong values, dynamic thinking

Over the years we have seen the world change. Technological, social and cultural innovations, together with climate change, are transforming our lives and the way we inhabit our spaces. The office, the home, public and private spaces are now hybrid environments that demand new design approaches.

In response to these ongoing changes the Quadrifoglio Group has made a pledge: to make design sustainable in order to improve our quality of life. A sense of ethics that pervades all of its actions. From the careful selection of top-quality raw materials through to the expert choice of the most evocative finishes, from the manual actions of its designers, who sketch out their initial ideas on a piece of paper, through to those of the machinery which sculpts it from the material with pinpoint precision.

Quadrifoglio Group, since 1991.

La nostra Identità

Valori fermi, pensiero dinamico

Nel corso degli anni, abbiamo visto cambiare il mondo. Le innovazioni tecnologiche, sociali e culturali e i cambiamenti climatici stanno trasformando la nostra vita e il modo in cui abitiamo gli spazi. L'ufficio, la casa, i luoghi pubblici e privati sono ormai ibridi e impongono nuove vie di pensiero alla progettazione.

In Quadrifoglio Group interpretiamo questi incessanti mutamenti attraverso un unico impegno: rendere sostenibile il design, per aumentare la qualità della vita. Un rigore etico che pervade ogni gesto. Dalla selezione accurata delle materie prime di assoluta qualità, fino alla scelta sapiente delle finiture più evocative, dal movimento delle mani dei designer, che tracciano su un foglio la prima manifestazione di un'idea, fino a quello del macchinario che con accuratezza millimetrica la scolpisce nella materia.

Quadrifoglio Group, dal 1991.





People and relations

Thoughts, ideas, intuition

There would be no places without the people that live there. There would be no design without ideas. There would be no Quadrifoglio Group without our workers, customers and partners.

At the Quadrifoglio Group every project stems from and for interpersonal relations; from the sharing of an idea by designers to the production of ergonomic furniture and through to the design of comfortable spaces perfect for personal interaction. We choose our partners on the basis of shared values. We share with all employees a style of work based on order, both exterior and interior. During the year we dedicate time to training in order to share knowledge and enrich our perspective. Social commitment, company welfare and the protection of personal safety: this is how we put our people at the centre.

Quadrifoglio Group, people first and foremost.

Persone e relazioni

Pensieri, idee, intuizioni

Non esisterebbero i luoghi senza le persone che li vivono. Non esisterebbe il design senza un'intuizione tra le mani. Non esisteremmo noi, senza i nostri collaboratori, clienti e partner.

In Quadrifoglio Group ogni progetto nasce dall'incontro e per l'incontro tra le persone. Da quando un'idea viene condivisa dai designer, alla produzione di arredi ergonomici, fino alla progettazione di ambienti confortevoli, dove abitare le relazioni. Selezioniamo i nostri partner sulla base di valori comuni. Condividiamo uno stile di lavoro improntato all'ordine, esteriore e interiore, con tutti i dipendenti. Dedichiamo del tempo durante tutto l'anno alla formazione, per contaminare i saperi e arricchire la nostra prospettiva. Impegno sociale, welfare aziendale e tutela della sicurezza: ecco come mettiamo le persone al centro.

Quadrifoglio Group, siamo prima di tutto persone.



Our commitment

Sustainability is an everyday action

Sustainability is awareness, vision, transformation. It is the ability to construct the future by taking action in the present, also by changing little things.

At the Quadrifoglio Group we work every day to ensure that Sustainability becomes pervasive: a way of thinking, working and living, to feel good today and even better tomorrow. An ethical value, to share collectively but also to practice individually. Our focus on improving company processes, with respect for the environment, is constant. From the streamlining of production to the attainment of international green certificates, from company welfare policies through to the creation of an open roundtable with our team dedicated to sustainability, in order to share goals and strategies. This is our commitment.

Quadrifoglio Group, informed ethics.

Il nostro impegno

La Sostenibilità è un atto quotidiano

La Sostenibilità è consapevolezza, visione, trasformazione. È la capacità di costruire il futuro agendo nel presente, anche attraverso piccoli gesti.

In Quadrifoglio Group ci impegniamo ogni giorno affinché la Sostenibilità diventi pervasiva: un modo di pensare, di lavorare e di vivere, per stare bene oggi e meglio domani. Un valore etico, da condividere collettivamente e da praticare anche individualmente. La nostra tensione verso il miglioramento dei processi aziendali, nel rispetto dell'ambiente, è costante. Dalla razionalizzazione della produzione, all'ottenimento delle certificazioni green internazionali, dalle politiche di welfare aziendale, fino alla creazione di un tavolo aperto con il nostro team dedicato alla sostenibilità, per condividere obiettivi e strategie.

Questo è il nostro impegno.

Quadrifoglio Group, etica consapevole.



The mark of responsible forestry

Look for our FSC™-certified products



Klavertje vier, Trèfle à quatre feuilles, Four-leaf clover, четырёхлистный клевер

An international empathy

In all languages and cultures, Made in Italy is synonymous with quality raw materials, attention to detail and elegance. We export our exclusive and universally-recognised approach and method to Europe and the rest of the world.

At the Quadrifoglio Group Made in Italy means being in touch with the needs of the present: familiarity with different cultures, understanding people's needs and designing solutions tailored to future habits. We speak the language of the foreign markets through an international style and, thanks to our sales and marketing departments, we communicate with our customers in their own languages because making people feel part of a family is the absolute epitome of care and professionalism in our opinion.

Quadrifoglio Group, Italy. World.

Klavertje vier, Trèfle à quatre feuilles, Four-leaf clover, четырёхлистный клевер

Un'empatia internazionale





In tutte le lingue e le culture, Made in Italy è sinonimo di qualità delle materie prime, attenzione ai dettagli ed eleganza. Esportiamo in Europa e in tutto il mondo un modo di essere e di fare esclusivo, riconosciuto universalmente.

In Quadrifoglio Group Made in Italy significa essere in ascolto delle necessità del presente: conoscere diverse culture, comprendere le esigenze delle persone e disegnare soluzioni a misura delle abitudini che verranno. Parliamo il linguaggio dei mercati esteri attraverso uno stile internazionale e, grazie ai nostri dipartimenti, commerciale e marketing, comunichiamo con i clienti nelle loro lingue madri, perché far sentire le persone come in famiglia per noi è la massima espressione di cura e professionalità.

Quadrifoglio Group, Italia. Mondo.







Decorative Lighting Index

| | |
|---|--|
|  TABLE LAMPS 06 - 55 |  FLOOR LAMPS 56 - 105 |
|  PENDANT LAMPS 106 - 237 |  WALL/CEILING LAMPS 238 - 307 |

Architectural Lighting Index

| | |
|---|--|
|  PENDANT LAMPS 308 - 330 |  WALL/CEILING LAMPS 308 - 330 |
|---|--|

Office Lighting Index

| | |
|---|---|
|  TABLE LAMPS 332 - 343 |  FLOOR LAMPS 344 - 361 |
|  PENDANT LAMPS 362 - 373 |  ACOUSTIC ELEMENTS 374 - 399 |

Decorative Lighting

**Light emotions.
Soft, sinuous or geometric
lines: decorative lamps are
available in different covers,
materials, textures and colours.
Every single detail is designed
to create an appealing
ambience in living, hospitality
and business interiors.**

Emozioni di luce.

Linee morbide, sinuose o geometriche: le lampade decorative sono disponibili in diversi rivestimenti, materiali, texture e colori. Ogni dettaglio è studiato per creare atmosfere suggestive in ambienti living, hospitality e business.

Products Index

Decorative Lighting



TABLE LAMPS

AFRA - 8
BALANCE - 14
CD LED - 20
GRACE - 32
HALF MOON - 38
OLA - 44
SUN - 50



FLOOR LAMPS

AFRA - 58
BABEL - 64
CD LED - 70
GRACE - 76
HALF MOON - 82
OLA - 88
WARM - 100



PENDANT LAMPS

ADD - 108
AFRA - 114
BABEL - 120
BLONDE - 126
CD LED - 132
DRINK - 140
ESCAPE - 146
GOUT - 152
GRACE - 158
HALF MOON - 164
MIRAGE - 170
OLA - 176
OLA FLY - 182
PIPES - 188
PLANET - 194
SLICE - 202
STARLIGHT - 208
SUN - 214
SVEVA - 220
TUBE - 226
TUBE MICRO - 232



WALL/CEILING LAMPS

ALALUNGA - 240
CD LED - 246
DRINK - 252
ESCAPE - 258
OLA SLIM - 264
SHADOW - 270
SLICE - 276
STARLIGHT - 282
TUBE - 288
TUPLA - 296
TURN ME! - 302

SYMBOL LEGEND

LEGENDA SIMBOLI

400

Family Index

Decorative Lighting



ADD

ADD PENDANT - 108

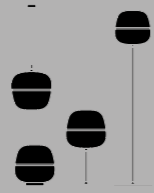

AFRA

AFRA TABLE - 8
AFRA FLOOR - 58
AFRA PENDANT - 114



ALALUNGA

ALALUNGA WALL - 240



BABEL

BABEL FLOOR - 64
BABEL PENDANT - 120

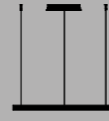

PLANET

PLANET PENDANT - 194



SHADOW

SHADOW WALL - 270



SLICE

SLICE PENDANT - 202
SLICE WALL/CEILING - 276

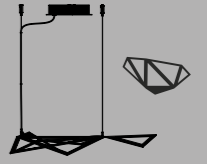

STARLIGHT

STARLIGHT PENDANT - 208
STARLIGHT WALL - 282



BALANCE

BALANCE TABLE - 14



BLONDE

BLONDE PENDANT - 126

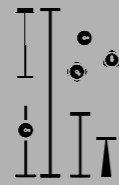

CD LED

CD LED TABLE - 20
CD LED FLOOR - 70
CD LED PENDANT - 132
CD LED WALL - 246



DRINK

DRINK PENDANT - 140
DRINK CEILING - 252



SUN

SUN TABLE - 50
SUN PENDANT - 214

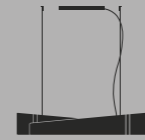

SVEVA

SVEVA PENDANT - 220



TUBE

TUBE PENDANT - 226
TUBE WALL/CEILING - 288



TUBE MICRO

TUBE MICRO PENDANT - 232

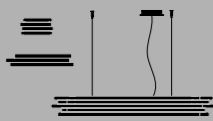

ESCAPE

ESCAPE PENDANT - 146
ESCAPE WALL - 258



GOUT

GOUT PENDANT - 152

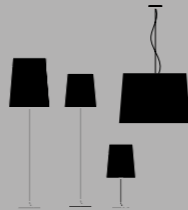

GRACE

GRACE TABLE - 32
GRACE FLOOR - 76
GRACE PENDANT - 158

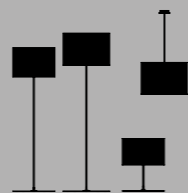

HALF MOON

HALF MOON TABLE - 38
HALF MOON FLOOR - 82
HALF MOON PENDANT - 164



TUPLA

TUPLA WALL - 296



TURN ME!

TURN ME! WALL - 302



WARM

WARM FLOOR - 100



MIRAGE

MIRAGE PENDANT - 170

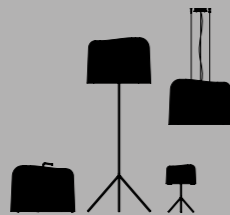

OLA

OLA TABLE - 44
OLA FLOOR - 88
OLA PENDANT - 176



OLA SLIM

OLA FLY PENDANT - 182
OLA SLIM WALL/CEILING - 264



PIPES

PIPES PENDANT - 188

Family Index

Decorative Lighting

Table Lamps

Decorative Lighting



Table lamps

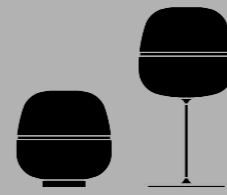

AFRA

AFRA TABLE - 8



BALANCE

BALANCE TABLE - 14

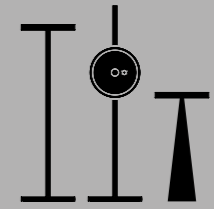

CD LED

CD LED TABLE - 20



GRACE

GRACE TABLE - 32



HALF MOON

HALF MOON TABLE - 38



OLA

OLA TABLE - 44



SUN

SUN TABLE - 50



**Opal transparency.
Opaline glass and painted
aluminium converge in the full-
bodied shape of Afra, available
in the version with pedestal
and support base. The light is
diffused and dimmable, ideal for
bedside cabinets, cupboards
and receptions.**

Trasparenze d'opale.

Vetro opalino e alluminio verniciato si incontrano nella forma piena di Afra, disponibile nelle versioni con piedistallo e base d'appoggio. La luce è diffusa e dimmerabile, ideale per comodini, madie, consolle e reception.



TABLE LAMPS



AFRA table lamp | Matt White acid-etched glass shade and Matt White base
BLOOM credenza | American Walnut doors and sides, Invisible White porcelain stoneware top and Umbra Grey legs





Table lamp

AFRA

Table lamp with white acid etched blown glass shade and powder coated metal frame.
Lampada da tavolo con paralume in vetro soffiato acidato bianco e base in metallo verniciato.

MAX 1XE27 100W
220-240V
ON-OFF | Dimmer

CE IP20 

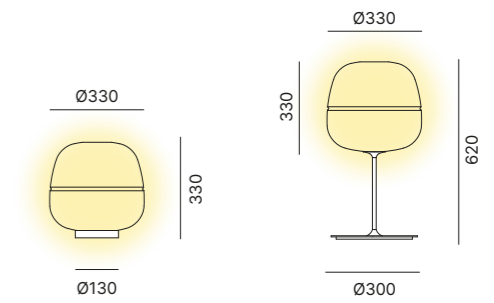

For the icon summary refer to pages 400 - 403 / Per la legenda icone vedere pp. 400 - 403

SHADE FINISH OPTIONS FINITURE PARALUME



White acid-etched glass

CAP (optional) CUFFIA (opzionale)

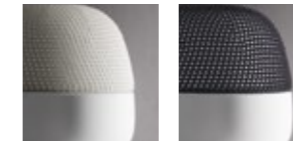

Beige

Black

FRAME FINISH OPTIONS FINITURE STRUTTURA



Matt White



Black Goffratino

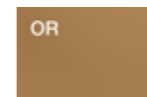

Gold



Bronze



Corten

Afra collection

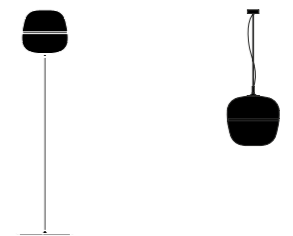

AFRA FLOOR
58

AFRA PENDANT
114

BALANCE

designed by Thomas Feichtner

Dynamic balance.
Balance arises from an essential design: tubular curved aluminium defines a minimal and slender structure that can be positioned horizontally or vertically, to direct light on the table in the office or in the home office.

Equilibrio dinamico.

Balance è frutto di un disegno essenziale: l'alluminio tubolare curvato tratteggia una struttura minimal e sottile, orientabile in orizzontale e in verticale per direzionare la luce sul tavolo in ufficio o nell'home office.



TABLE LAMPS



BALANCE table lamp | Matt White
X9 executive desk | Elm top and Matt White legs
DIVA SOFT executive chair | C05/280 fabric and Chrome frame

Lighting & Acoustic Collection

DESIGN LIGHTING





Table lamp

BALANCE

Table lamp in white or black painted aluminium.
Lampada da tavolo in alluminio verniciato bianco o nero.

4,8W LED
110-240V
2700 K
CRI80
ON-OFF

CE IP20   120lm UGR₁₉

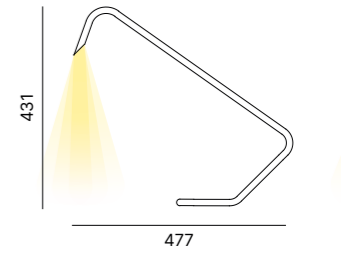
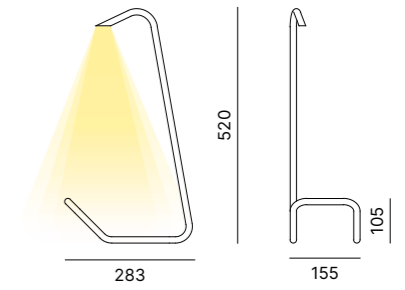

For the icon summary refer to pages 400 - 403 / Per la legenda icone vedere pp. 400 - 403

LAMP FINISH OPTIONS FINITURE LAMPADA



Matt White

Black Goffratino



designed by Moreno De Giorgio

**Geometries of style.
An minimalistic lamp, with
a sophisticated soul and an
assemblable structure.
CD Led can be customised in
terms of shape and colour, to
adapt it to tables in different
settings, including residential
and hospitality use.**

Geometrie di stile.

Una lampada minimale, con un'anima sofisticata e una struttura multiforme: CD Led si può personalizzare nelle forme e nei colori per adattarla ai tavoli di diversi contesti, residenziali e ricettivi.



TABLE LAMPS





The CD Led base is available in a conical or circular version and the structure can be completed with a geometric element, available in a circular, square or triangular shape and customisable in numerous colours.

Il basamento di CD Led è disponibile in versione conica o circolare e la struttura si può completare con un elemento geometrico a scelta tra cerchio, quadrato e triangolo, customizzabile in numerosi colori.

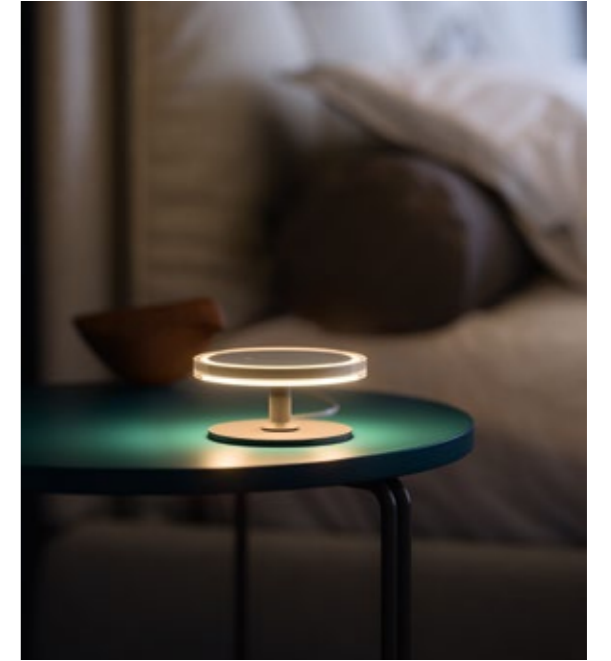



The powerful led light is adjustable with a mechanical dimmer, ideal for lighting reception areas, coffee tables, living room tables and bedside cabinets with personality.

La luce a led è potente e regolabile tramite un meccanismo dimmer, ideale per illuminare con personalità reception, tavolini, tavoli della zona giorno e comodini dell'area notte.







Table lamp

CD LED

Polycarbonate lamp diffuser with transparent or colored PMMA ring, powder coated metal frame.
 Diffusore in policarbonato con anello in PMMA trasparente o colorato, struttura in metallo verniciato.

9,5W LED
 110-240V
 2700K
 CRI90
 Gesture dimm

CE IP20   24V 1250lm  MacAdam Step 3

UGR₁₉

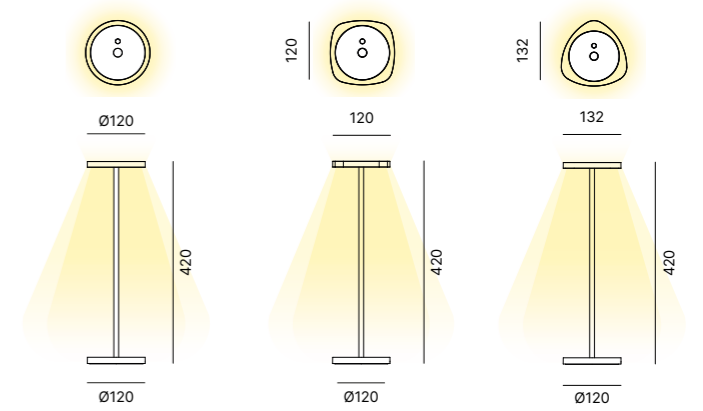

For the icon summary refer to pages 400 - 403 / Per la legenda icone vedere pp. 400 - 403

FINISH OPTIONS
 FINITURE

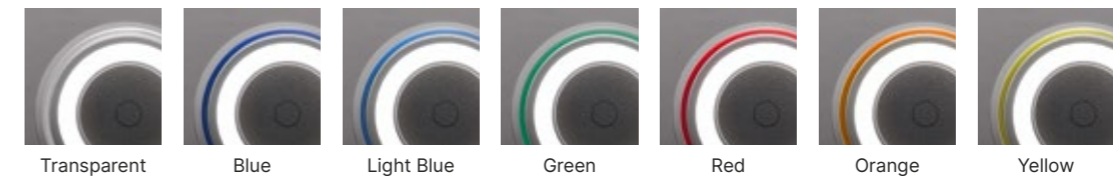

FRAME FINISH OPTIONS
 FINITURE STRUTTURA



Matt Black

CD Led collection

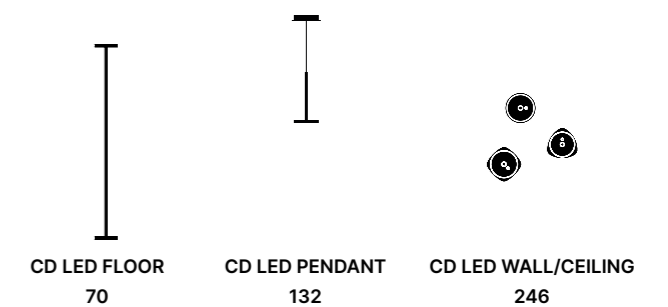



Table lamp

CD LED

Polycarbonate lamp diffuser with transparent or colored PMMA ring, powder coated metal frame.
 Diffusore in policarbonato con anello in PMMA trasparente o colorato, struttura in metallo verniciato.

9,5W LED
 110-240V
 2700K
 CRI90
 Gesture dimm

CE IP20 LED 24V 1250lm MacAdam Step 3
 UGR₁₉

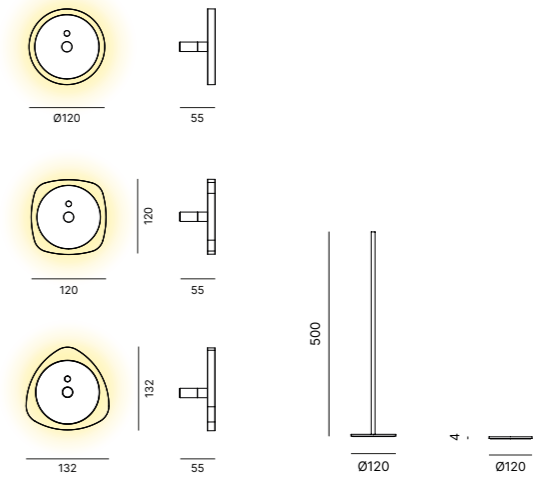

For the icon summary refer to pages 400 - 403 / Per la legenda icone vedere pp. 400 - 403

FINISH OPTIONS
 FINITURE

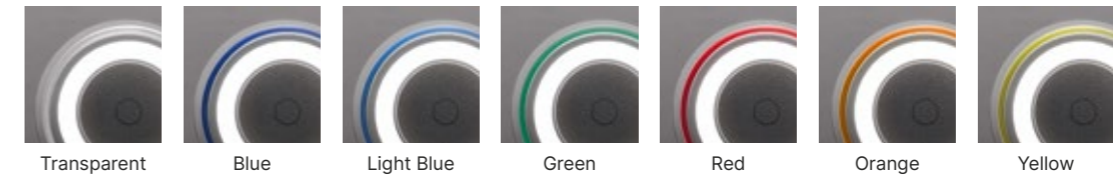

FRAME FINISH OPTIONS
 FINITURE STRUTTURA



Matt Black

CD Led collection

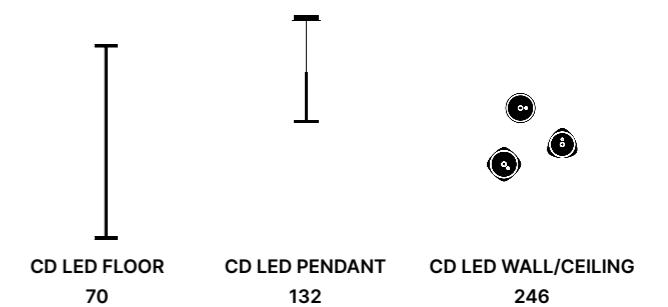

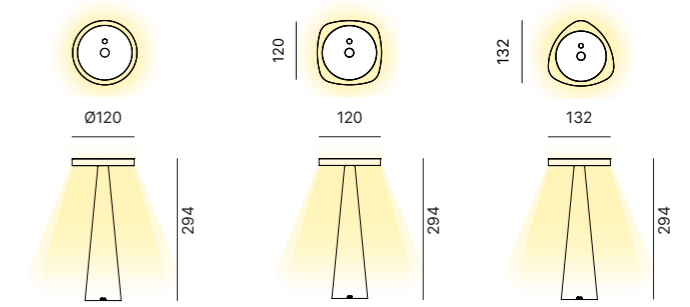

Table lamp

CD LED

Polycarbonate lamp diffuser with transparent or colored PMMA ring, powder coated metal frame.
 Diffusore in policarbonato con anello in PMMA trasparente o colorato, struttura in metallo verniciato.

3W LED
 110-240V
 2700K
 CRI90
 Touch dimm



CE IP20    MacAdam Step 3

For the icon summary refer to pages 400 - 403 / Per la legenda icone vedere pp. 400 - 403

FINISH OPTIONS FINITURE

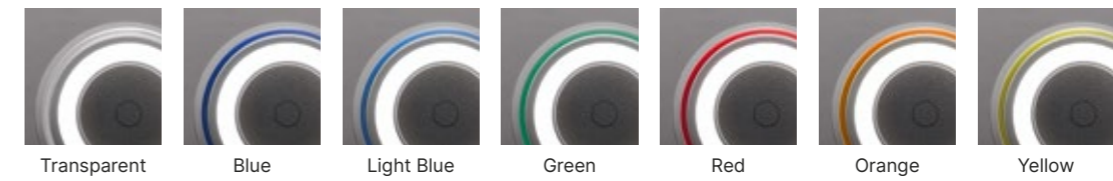

FRAME FINISH OPTIONS FINITURE STRUTTURA



Matt Black

CD Led collection

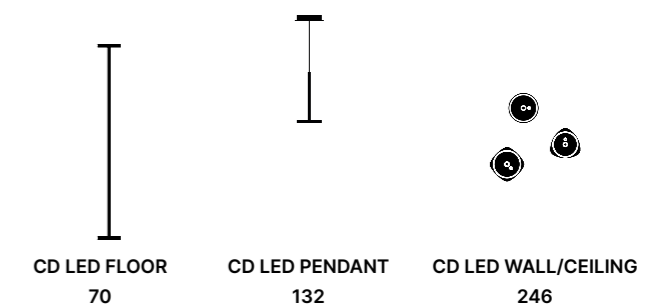



designed by Moreno De Giorgio

**Renewed imagination.
Grace reinterprets the traditional
shape of the lamp through
original finishings, from the
round and perforated base to the
shade fabric: a highly suitable
solution for residential interiors
and executive business settings
alike.**

Immaginario rinnovato.

Grace reinterpreta la forma tradizionale della lampada attraverso finiture inedite, dal basamento circolare forato, fino al tessuto del paralume: una soluzione che ben si presta sia per ambienti residenziali sia per spazi di business direzionali.



TABLE LAMPS



GRACE table lamp | Black Goffratino frame and Black Cotton shade
X5 desk | Umbra Grey legs and Eucalyptus top
CITY design chair | E04/488 fabric and Gold frame
P1 Boiserie | Eucalyptus panels and shelves





Table lamp

Table lamp with powder coated metal frame, linen or cotton shade.

Lampada da tavolo con stelo in metallo verniciato, paralume in lino o cotone.

MAX 1XE27 100W
220-240V
ON-OFF | Dimmer

CE IP20 

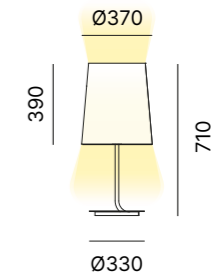

For the icon summary refer to pages 400 - 403 / Per la legenda icone vedere pp. 400 - 403

SHADE FINISH OPTIONS FINITURE PARALUME



Natural Linen Black Cotton

FRAME FINISH OPTIONS FINITURE STRUTTURA



Black Goffratino Gold Bronze Corten

Grace collection

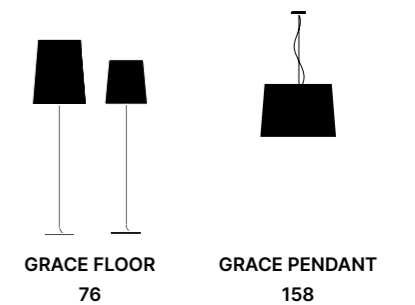

GRACE FLOOR
76

GRACE PENDANT
158

HALF MOON

designed by Enrico Franzolini & Vicente García Jimenez

**Concrete style.
Classical shapes and multi-
faceted nature: Half Moon is the
right table lamp for enhancing
residential, business and
hospitality settings.
The stem can be customised
in the colours black goffratino,
bronze, gold and corten, for a
precious touch.**

38

Stile concreto.

Forme classiche e natura poliedrica: Half Moon è la lampada da tavolo giusta per valorizzare spazi residenziali, business e hospitality. Lo stelo è personalizzabile nei colori nero goffratino, bronzo, oro e corten, per un tocco prezioso.



TABLE LAMPS



39



The shade of Half Moon is made of linen or cotton and can be fitted with a neutral or coloured inner cover. Available tonalities combine with the light when on, warming the ambience of interiors.

Il paralume di Half Moon è in lino o in cotone e si può dotare all'interno di un rivestimento coprente, neutro o colorato. Le tonalità a disposizione, abbinata alla luce accesa, scaldano l'atmosfera degli ambienti.



Table lamp

HALF MOON

Table lamp with powder coated metal frame, linen or cotton shade with white or colored inside.

Lampada da tavolo con stelo in metallo verniciato, paralume in lino o cotone con interno coprente bianco o colorato.

MAX 1XE27 100W
220-240V
ON-OFF | Dimmer

CE IP20

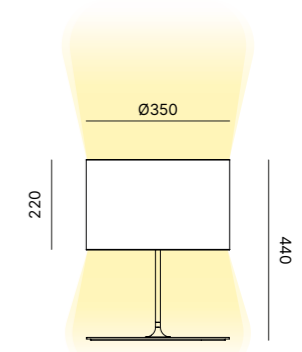

For the icon summary refer to pages 400 - 403 / Per la legenda icone vedere pp. 400 - 403

SHADE FINISH OPTIONS FINITURE PARALUME



Black Cotton White inside Black Cotton Yellow inside Black Cotton Orange inside Black Cotton Fuchsia inside Natural Linen White inside Natural Linen Yellow inside Natural Linen Orange inside Natural Linen Fuchsia inside

FRAME FINISH OPTIONS FINITURE STRUTTURA

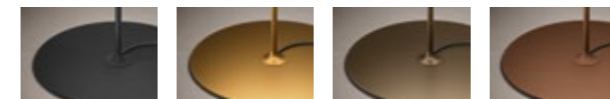

Black Goffratino Gold Bronze Corten

Half Moon collection

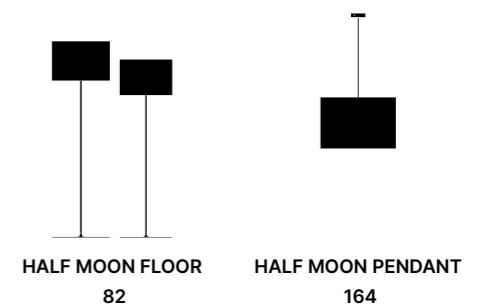

HALF MOON FLOOR
82

HALF MOON PENDANT
164



designed by Enrico Franzolini

**Technology and material.
Designed for hospitality
and residential interiors, Ola
combines formal research
and material, culminating
in an iconic lamp featuring
a painted metal stem and
fibreglass shade.**

Tecnologia e materia.

Progettata per ambiti hospitality e residenziali, Ola è la sintesi di una ricerca formale e materiale: nasce così questa lampada iconica, con stelo in metallo verniciato e paralume in fibra di vetro.



TABLE LAMPS





OLA table lamp | Black Goffratino frame and White fibreglass shade
BLOOM credenza | Noir Desir porcelain stoneware doors, Umbra Grey lacquered top and sides, Bronze Flair legs



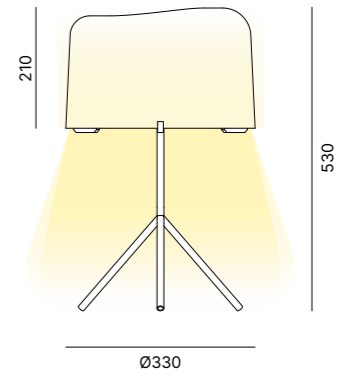

Table lamp

Table lamp with fibreglass shade and black powder coated metal frame.
Lampada da tavolo con paralume in fibra di vetro, stelo in metallo verniciato nero.

MAX 1XE27 100W
220-240V
ON-OFF | Dimmer

CE IP20 



For the icon summary refer to pages 400 - 403 / Per la legenda icone vedere pp. 400 - 403

SHADE FINISH OPTIONS FINITURE PARALUME



White fibreglass Red fibreglass Orange fibreglass Gold fibreglass Silver fibreglass

FRAME FINISH OPTIONS FINITURE STRUTTURA



Black Goffratino

Ola collection

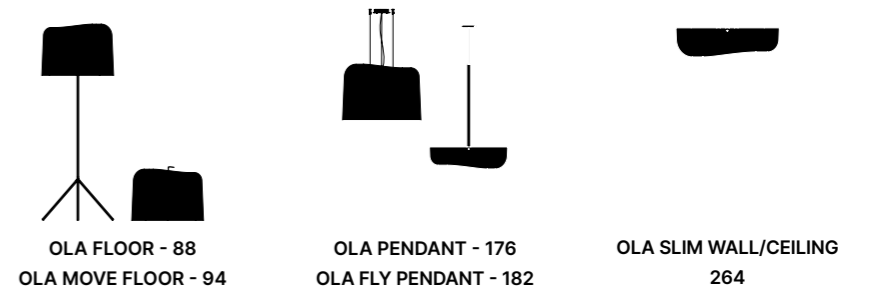

OLA FLOOR - 88
OLA MOVE FLOOR - 94

OLA PENDANT - 176
OLA FLY PENDANT - 182

OLA SLIM WALL/CEILING
264

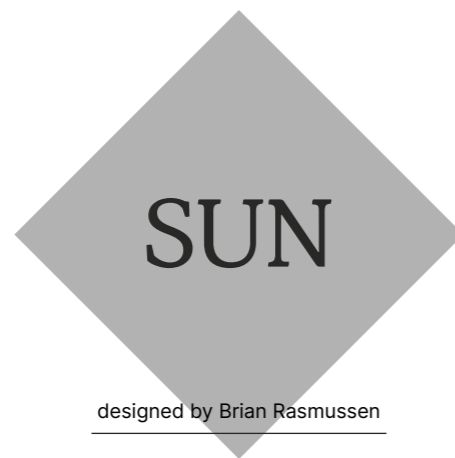

**Broken down light.
Ideal for original and
creative settings, Sun
consists of a metal base
and a shade available in 3
tonalities, which fragments
and reflects light, with no
less than 96 fabric parts.**

Luce scomposta.
Ideale per ambienti ricercati e creativi, Sun è formata da una base in metallo e un paralume, disponibile in 3 tonalità, che frammenta e riflette la luce, grazie alla lavorazione di 96 parti di tessuto.



TABLE LAMPS



SUN table lamp | Matt White frame and White fabric shade
BLOOM credenza | American Walnut doors, sides and top, Bronze legs





Table lamp

SUN

Table lamp with fabric shade and matt white powder coated metal frame.

Lampada da tavolo con paralume in tessuto e stelo in metallo verniciato bianco opaco.

MAX 1XE27 100W
220-240V
ON-OFF | Dimmer

CE IP20

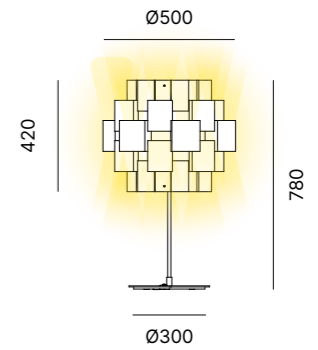

For the icon summary refer to pages 400 - 403 / Per la legenda icone vedere pp. 400 - 403

SHADE FINISH OPTIONS FINITURE PARALUME



White fabric Black fabric Red fabric

FRAME FINISH OPTIONS FINITURE STRUTTURA



Matt White

Sun collection

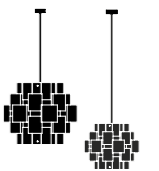

SUN PENDANT
214

Floor Lamps

Decorative Lighting



Floor lamps



AFRA

AFRA FLOOR - 58



BABEL

BABEL FLOOR - 64



CD LED

CD LED FLOOR- 70



GRACE

GRACE FLOOR - 76



HALF MOON

HALF MOON FLOOR - 82

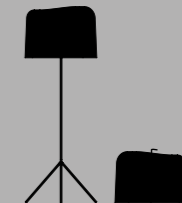

OLA

OLA FLOOR - 88
OLA MOVE FLOOR - 94



WARM

WARM FLOOR - 100



**A globe of light.
The aluminium structure
culminates in a bubble
of opaline glass light,
customisable with a
handmade fabric cover:
Afra is the perfect lamp for
refined and shared settings.**

**Globo di luce.
La struttura in alluminio culmina in una bolla di
luce in vetro opalino, personalizzabile con una
cuffia in tessuto fatta a mano: Afra è la lampada
perfetta per ambienti raffinati e condivisi.**





AFRA floor lamp | Matt White acid-etched glass shade and Matt White frame
CLEOPAS armchair and ottoman | D04/397 fabric and Umbra Grey base
ALTER EGO mirrors



Floor lamp

AFRA

Floor lamp with white acid etched blown glass shade and powder coated metal frame.

Lampada da terra con paralume in vetro soffiato acidato bianco e base in metallo verniciato.

MAX 1XE27 100W
220-240V
ON-OFF | Dimmer

CE IP20 

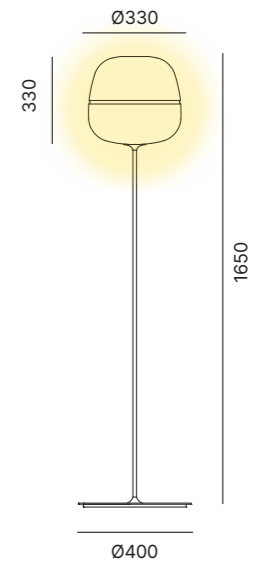

For the icon summary refer to pages 400 - 403 / Per la legenda icone vedere pp. 400 - 403

SHADE FINISH OPTIONS FINITURE PARALUME



White acid-etched glass

CAP (optional) CUFFIA (opzionale)

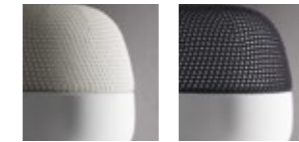

Beige

Black

FRAME FINISH OPTIONS FINITURE STRUTTURA



Matt White



Black Goffratino

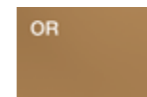

Gold



Bronze



Corten

Afra collection

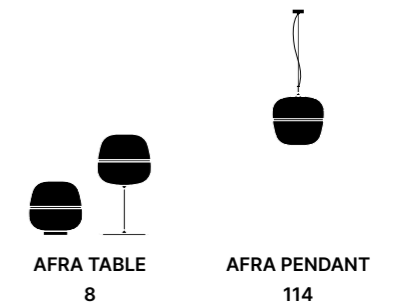



**Ancient genesis.
The shade is inspired by
the legendary unfinished
tower of Babel and replicates
its ascending shape in the
fabric shade, supported by
a metal tripod: a suitable
design for public and private
settings alike.**

Genesi antica.

La lampada si ispira alla mitica torre incompiuta di Babele e ne replica la forma ascendente nel paralume in tessuto, poggiato su un treppiede in metallo: un design adatto per spazi pubblici e privati.



FLOOR LAMPS



BABEL floor lamp | Black fabric shade and Black Goffratino frame
MONTREAL side table | Fokos Piombo porcelain stoneware top and Umbra Grey frame





Floor lamp

BABEL

Floor lamp with honeycomb fabric shade and powder coated metal frame.
Paralume in tessuto a nido d'ape, base in metallo verniciato.

MAX 3XE27 60W
220-240V
ON-OFF | Dimmer

CE  IP20

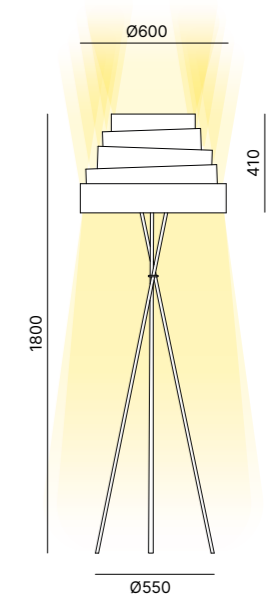

For the icon summary refer to pages 400 - 403 / Per la legenda icone vedere pp. 400 - 403

SHADE FINISH OPTIONS FINITURE PARALUME



FRAME FINISH OPTIONS FINITURE STRUTTURA



Babel collection



BABEL PENDANT
120



designed by Moreno De Giorgio

**Flexible identity.
Ideal as a reading lamp or
as an ambience-setting
light point for domestic and
hospitality interiors, CD Led
features an minimalistic and
customisable design that
characterises all settings
with a tailored style.**

**Identità flessibile.
Ideale come lampada da lettura o come punto luce
d'atmosfera per spazi domestici e ricettivi,
CD Led ha un design minimal e personalizzabile, per
caratterizzare ogni ambiente con uno stile su misura.**



FLOOR LAMPS



CD LED floor lamps | Matt Black
ARTE sofa | M01/554 fabric

Lighting & Acoustic Collection



DESIGN LIGHTING



Floor lamp

CD LED

Polycarbonate lamp diffuser with transparent or colored PMMA ring, powder coated metal frame.
 Diffusore in policarbonato con anello in PMMA trasparente o colorato, struttura in metallo verniciato.

9,5W LED
 110-240V
 2700K
 CRI90
 Gesture dimm

CE IP20 LED 24V 1250lm MacAdam Step 3
 UGR₁₉

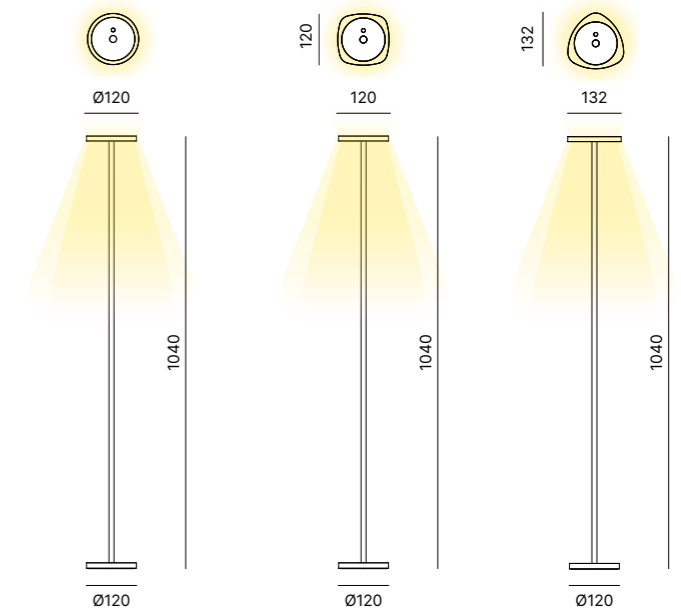

For the icon summary refer to pages 400 - 403 / Per la legenda icone vedere pp. 400 - 403

FINISH OPTIONS
 FINITURE

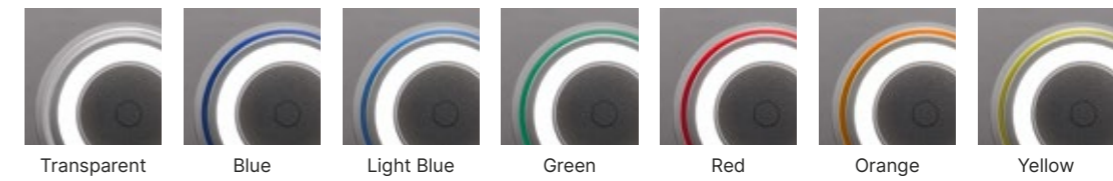

FRAME FINISH OPTIONS
 FINITURE STRUTTURA



Matt Black

CD Led collection

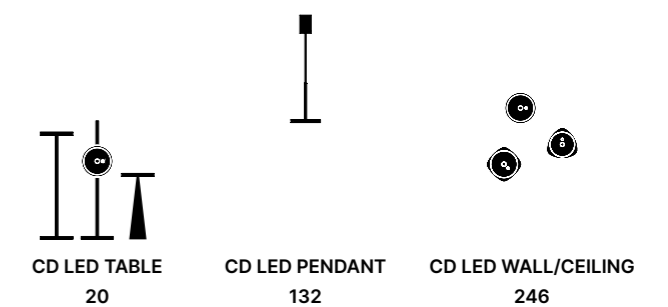



designed by Moreno De Giorgio

**Natural aesthetics.
Grace exquisitely adapts to
different settings, thanks
to its two versions, small
and big. Its classical shapes
are exalted by original
finishings, like the natural
linen or black cotton shade.**

Estetica naturale.

Grace si adatta con garbo a diversi ambienti, grazie alle due versioni, piccola e grande, e alle forme classiche esaltate da finiture ricercate, come il paralume in lino naturale o cotone nero.



FLOOR LAMPS



GRACE floor lamps | Natural Linen shade and Black Goffratino frame
MELBOURNE pouf | E03/464 fabric and Oak varnished solid ash wood legs
MELBOURNE side table | Fokos Terra porcelain stoneware top and Oak varnished solid ash wood legs
CITY DÉCO LOUNGE armchair | E04/476 fabric and Bronze frame



Floor lamp

GRACE

Floor lamp with powder coated metal frame, linen or cotton shade.

Lampada da terra con stelo in metallo verniciato, paralume in lino o cotone.

Grace small

MAX 1XE27 100W
220-240V
ON-OFF | Dimmer

Grace

MAX 3XE27 60W
220-240V
ON-OFF | Dimmer

CE IP20 

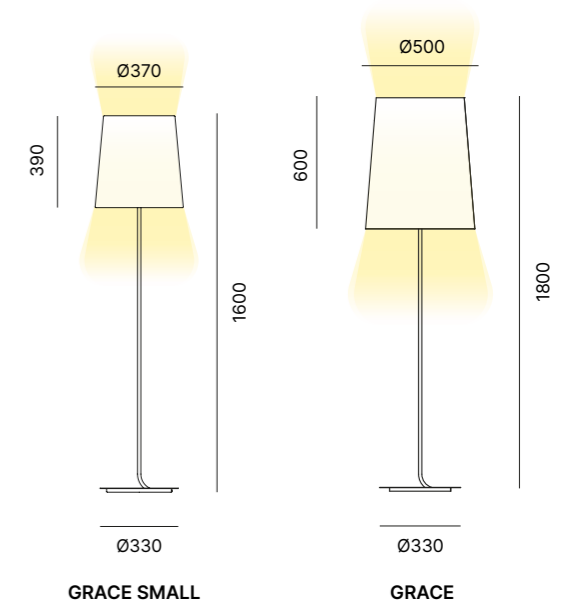

For the icon summary refer to pages 400 - 403 / Per la legenda icone vedere pp. 400 - 403

SHADE FINISH OPTIONS FINITURE PARALUME

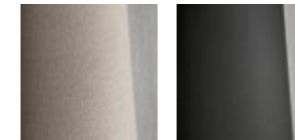

Natural Linen Black Cotton

FRAME FINISH OPTIONS FINITURE STRUTTURA



Black Goffratino Gold Bronze Corten

Grace collection

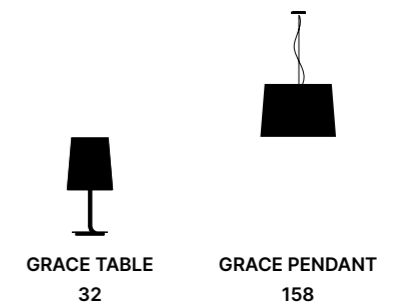

HALF MOON

designed by Enrico Franzolini & Vicente García Jimenez

**Timelessly classic.
Half Moon is the perfect
lamp for all shared spaces:
it is ideal next to armchairs,
sofas and ottomans and can
be customised with different
colour options. It is available in a
big or small version, to enhance
interiors of different sizes.**

Classico attuale.

Half Moon è la lampada perfetta per qualsiasi spazio di condivisione: ideale accanto a poltrone, divani e pouf, è personalizzabile nei colori e disponibile in versione grande o piccola, per valorizzare ambienti di diversa metratura.



FLOOR LAMPS



HALF MOON floor lamp | Black Goffratino frame and Black Cotton shade
ARCO armchair | Walnut varnished solid ash wood arms and D02/268 fabric
MONTREAL side table | Invisible White porcelain stoneware top and Umbra Gray frame



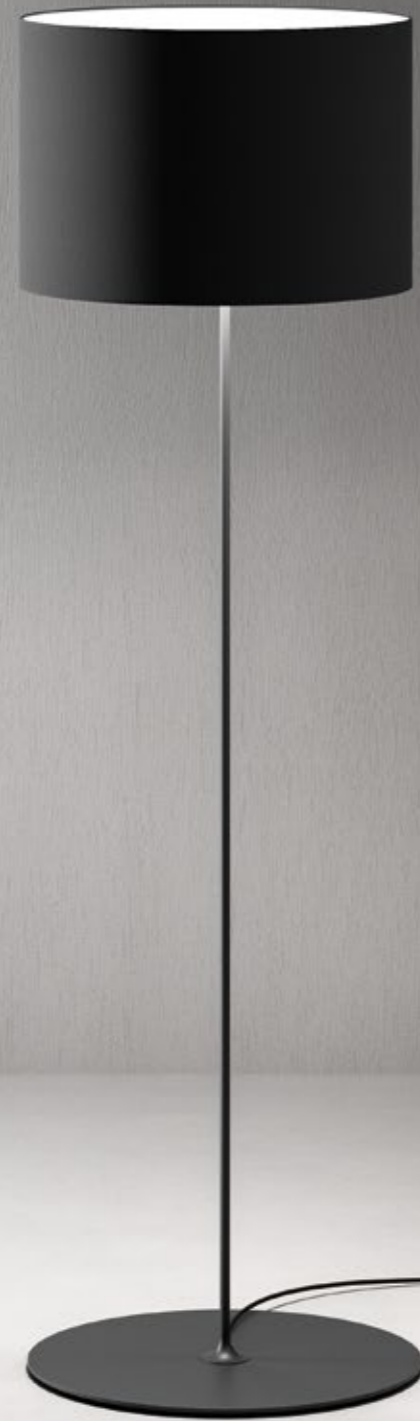

Floor lamp

HALF MOON

Floor lamp with powder coated metal frame, linen or cotton shade with white or colored inside.
Lampada da terra con stelo in metallo verniciato, paralume in lino o cotone con interno coprente bianco o colorato.

Half Moon small
MAX 1XE27 100W
220-240V
ON-OFF | Dimmer

Half Moon
MAX 3XE27 60W
220-240V
ON-OFF | Dimmer

CE IP20

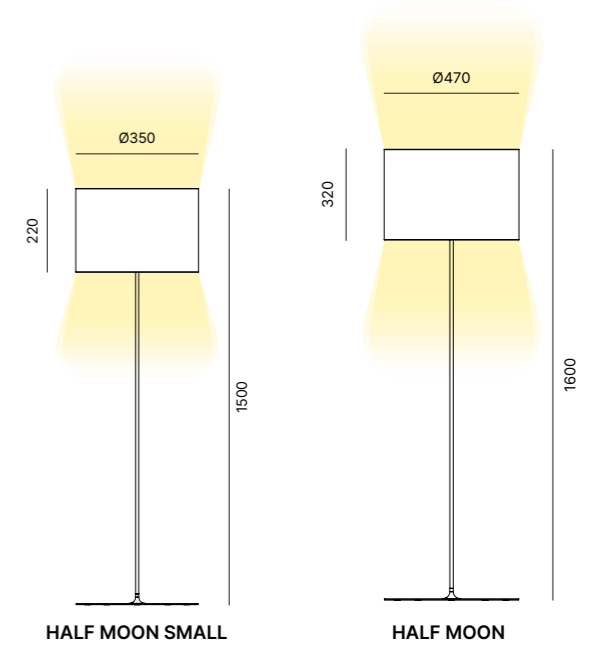

For the icon summary refer to pages 400 - 403 / Per la legenda icone vedere pp. 400 - 403

SHADE FINISH OPTIONS
FINITURE PARALUME



FRAME FINISH OPTIONS
FINITURE STRUTTURA



Half Moon collection

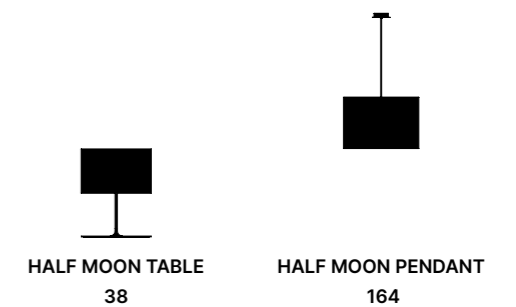



**Materialised sensation.
Original materials and
unprecedented shapes
interpret a new concept
of lighting. Ola is the floor
lamp that turns light into
ambience, thanks to the
fibreglass shade available
in five colours.**

**Sensazione materializzata.
Materiali inediti e forme originali interpretano un nuovo concetto di
illuminazione: Ola è la lampada da terra capace di trasformare la luce in
atmosfera, grazie a cinque colorazioni del paralume in fibra di vetro.**





OLA floor lamp | Black Goffratino frame and White fibreglass shade
AGIO armchair | E04/475 fabric and Chrome frame
ARTE sofa | D04/384 fabric and Chrome legs
MONTREAL metal pot | Bronze



Floor lamp

OLA

Floor lamp with fibreglass shade and black powder coated metal frame.

Lampada da terra con paralume in fibra di vetro, stelo in metallo verniciato nero.

MAX 3XE27 60W
220-240V
ON-OFF | Dimmer

CE IP20 

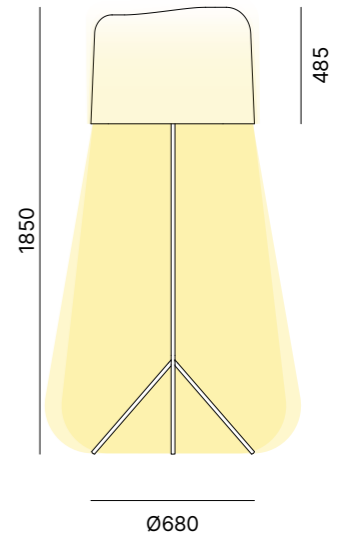

For the icon summary refer to pages 400 - 403 / Per la legenda icone vedere pp. 400 - 403

SHADE FINISH OPTIONS FINITURE PARALUME



White fibreglass

Red fibreglass

Orange fibreglass

Gold fibreglass

Silver fibreglass

FRAME FINISH OPTIONS FINITURE STRUTTURA



Black Goffratino

Ola collection



OLA TABLE
44



OLA MOVE FLOOR
94

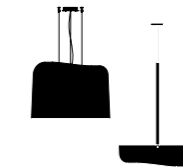

OLA PENDANT - 176
OLA FLY PENDANT - 182



OLA SLIM WALL/CEILING
264

OLA MOVE

designed by Enrico Franzolini

**Stylish movement.
Warm, inviting and diffused
lighting. Ola Move is the floor
lamp available in five colours,
for furnishing professional
and residential interiors. It can
be moved anywhere thanks to
the practical metal handle.**

Movimento di stile.

Illuminazione calda, accogliente e diffusa: Ola Move è la lampada da terra disponibile in cinque colori per arredare ambienti professionali e residenziali. Si trasporta ovunque grazie alla pratica maniglia in metallo.



FLOOR LAMPS



OLA MOVE floor lamp | White fibreglass shade
CITY LOUNGE armchair | D05/413 fabric and Oak varnished solid ash wood legs
MELBOURNE side table | Fokos Terra porcelain stoneware top and Oak varnished solid ash wood legs

Lighting & Acoustic Collection

DESIGN LIGHTING





Floor lamp

OLA MOVE

Floor lamp with fibreglass shade and black powder coated metal handle.

Lampada da terra con paralume in fibra di vetro, maniglia in metallo verniciato nero.

MAX 3XE27 60W
220-240V
ON-OFF | Dimmer

CE IP20 

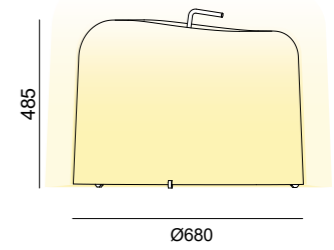

For the icon summary refer to pages 400 - 403 / Per la legenda icone vedere pp. 400 - 403

SHADE FINISH OPTIONS FINITURE PARALUME

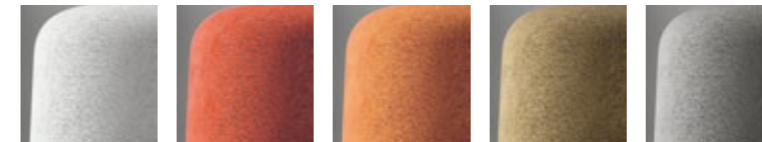

White fibreglass

Red fibreglass

Orange fibreglass

Gold fibreglass

Silver fibreglass

FRAME FINISH OPTIONS FINITURE STRUTTURA



Black Goffratino

Ola collection



OLA TABLE
44

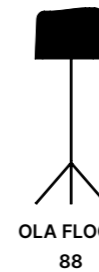

OLA FLOOR
88

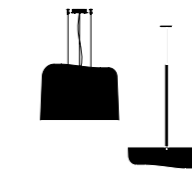

OLA PENDANT - 176
OLA FLY PENDANT - 182



OLA SLIM WALL/CEILING
264



**Enlightened mood.
Available in an indoor and
outdoor version, with decorative
fabric mesh upon request, Warm
characterises settings with
its soft and undulating profile,
providing lighting thanks to an
internal diffuser.**

**Mood luminoso.
Disponibile in versione indoor e outdoor, con rete
decorativa in tessuto su richiesta, Warm caratterizza gli
spazi con il suo profilo morbido e ondulato e li illumina
grazie a un diffusore interno.**



WARM floor lamp | White polyethylene shade and Black Goffratino frame
COVE outdoor chair | White frame and D06/507 simil leather upholstered seat
COZY coffee table | White frame and top





Floor lamp

WARM

Floor lamp with white polyethylene shade and zinc-plated steel base. Indoor and outdoor version available.
Lampada da terra con diffusore in polietilene bianco e base in metallo zincato. Disponibile in versione indoor e outdoor.

MAX 1XE27 100W
220-240V
ON-OFF | Dimmer

CE IP20 IP68 

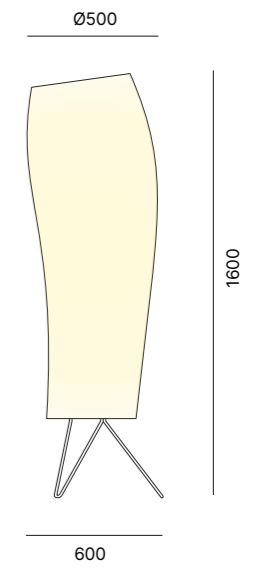

For the icon summary refer to pages 400 - 403 / Per la legenda icone vedere pp. 400 - 403

SHADE FINISH OPTIONS FINITURE PARALUME



White polyethylene

MESH (optional) RETE (opzionale)



White

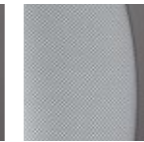

Black

FRAME FINISH OPTIONS FINITURE STRUTTURA



Black Goffratino

Pendant Lamps

Decorative Lighting



Pendant lamps



ADD

ADD PENDANT - 108



AFRA

AFRA PENDANT - 114



BABEL

BABEL PENDANT - 120



BLONDE

BLONDE PENDANT - 126



CD LED

CD LED PENDANT - 132



DRINK

DRINK PENDANT - 140

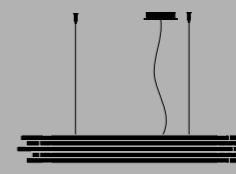

ESCAPE

ESCAPE PENDANT - 146



GOUT

GOUT PENDANT - 152



GRACE

GRACE PENDANT - 158



HALF MOON

HALF MOON PENDANT - 164



MIRAGE

MIRAGE PENDANT - 170

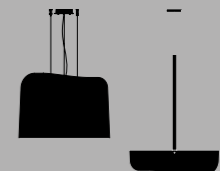

OLA

OLA PENDANT - 176
OLA FLY PENDANT - 182



PIPES

PIPES PENDANT - 188

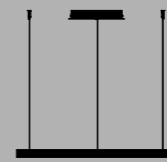

PLANET

PLANET PENDANT - 194



SLICE

SLICE PENDANT - 202



STARLIGHT

STARLIGHT PENDANT - 208

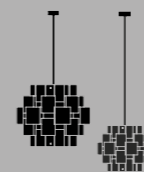

SUN

SUN PENDANT - 214

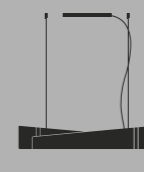

SVEVA

SVEVA PENDANT - 220



TUBE

TUBE PENDANT - 226
TUBE MICRO PENDANT - 232

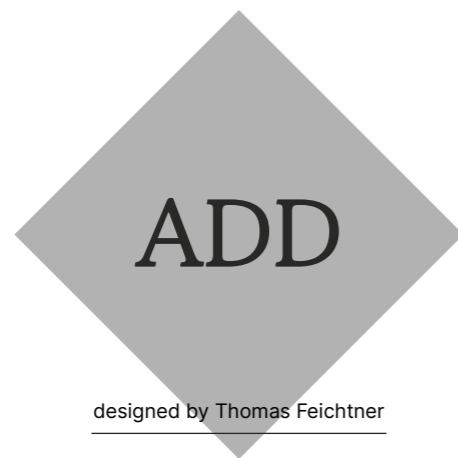

designed by Thomas Feichtner

**A sprinkle of light.
 Ideal for hospitality and
 business settings, Add is a
 play of reflections: the circular
 opening at the top of the
 ceramic shade generates a
 dynamism between the white
 interior and the varnished
 colour exterior.**

Pioggia di luce.

Ideale per spazi ricettivi e business, Add è un gioco di riflessi:
 l'apertura circolare sulla sommità del paralume in ceramica crea
 dinamismo tra l'interno bianco e l'esterno rifinito in smalto colorato.



PENDANT LAMPS



ADD pendant lamps | Glossy White and Glossy Bronze shade
AVANA composable sofa | D04/383 fabric and Umbra Grey legs





Pendant lamp

ADD

Pendant lamp with pottery shade in different colors with glossy white inside.

Lampada a sospensione con paralume in ceramica in varie finiture con interno smaltato bianco lucido.

MAX 1XE27 100W
220-240V
T/fase

CE IP20 

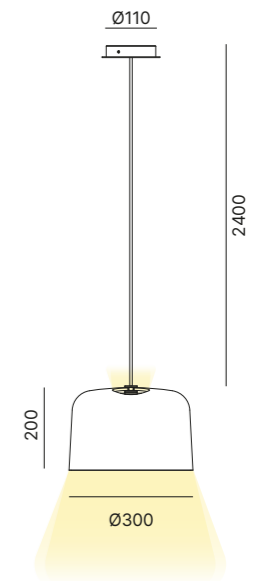

For the icon summary refer to pages 400 - 403 / Per la legenda icone vedere pp. 400 - 403

SHADE FINISH OPTIONS
FINITURE PARALUME

Glossy White

Glossy Bronze

Glossy Orange

Glossy Blue

Glossy Green

Matt Clay

CEILING ROSE
ROSONE

Matt White

DETAILS
DETTAGLI



**Resplendent pearl.
Afra is an elegant
ambience-setting lamp:
the blown glass sphere
embraces a hand-woven
cover, available in unique
textures that filter light in
different ways.**

**Perla splendente.
Afra è una lampada elegante e d'atmosfera: il globo di vetro
soffiato accoglie una cuffia tessuta a mano, disponibile in
texture uniche che filtrano la luce in modi sempre diversi.**



PENDANT LAMPS



AFRA pendant lamps | Matt White acid-etched glass shade and Matt White frame
SIX table | Umbra Grey frame and Invisible White porcelain stoneware top





Pendant lamp

AFRA

Pendant lamp with white acid etched blown glass shade and powder coated metal frame.

Lampada a sospensione con paralume in vetro soffiato acidato bianco e struttura in metallo verniciato.

MAX 1XE27 100W
220-240V
T/fase

CE IP20 

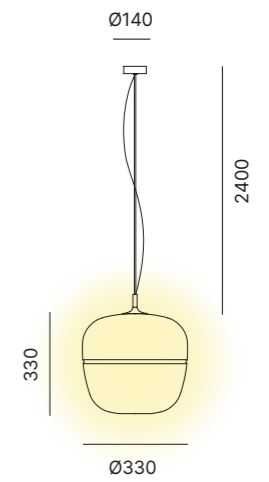

For the icon summary refer to pages 400 - 403 / Per la legenda icone vedere pp. 400 - 403

SHADE FINISH OPTIONS
FINITURE PARALUME

White acid-etched glass

CAP (optional)
CUFFIA (opzionale)

Beige

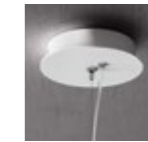

Black

CEILING ROSE
ROSONE

Matt White

FRAME FINISH OPTIONS
FINITURE STRUTTURA

Matt White



Black Goffratino

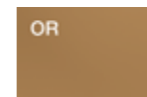

Gold



Bronze



Corten

Afra collection

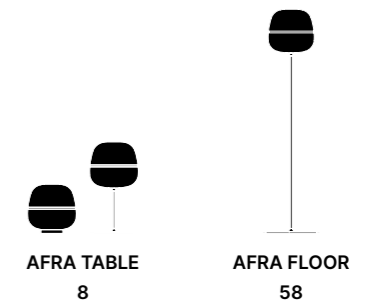



**Legendary allure.
The honeycomb fabric
shade of the Babel lamp
is inspired by the shape
of the biblical tower, in an
enveloping spiral around
the white painted metal
support.**

**Fascino leggendario.
Il paralume in tessuto a nido d'ape della lampada Babel si ispira
alla forma della torre biblica, in una spirale che si avvolge per
raggiungere il supporto in metallo verniciato bianco.**



PENDANT LAMPS



BABEL pendant lamp | White fabric shade
X9 meeting table | American Walnut top and Umbra Grey frame

Lighting & Acoustic Collection

DESIGN LIGHTING

122

123





124

BABEL pendant lamp | Black fabric shade

Pendant lamp

BABEL

Pendant lamp with honeycomb fabric shade.
Lampada a sospensione con paralume in tessuto a nido d'ape.

MAX 3XE27 60W
220-240V
T/fase

CE IP20

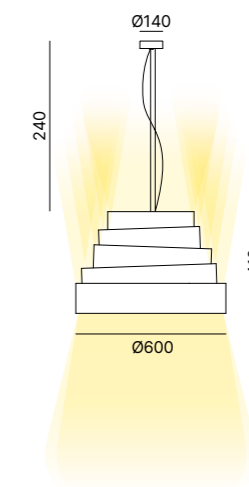

DESIGN LIGHTING

For the icon summary refer to pages 400 - 403 / Per la legenda icone vedere pp. 400 - 403

SHADE FINISH OPTIONS
FINITURE PARALUME

White

Black

CEILING ROSE
ROSONE

Matt White

Babel collection

BABEL FLOOR
64

125



**Eclectic imagination.
The trapezoidal shape
decisively characterises
settings: in the kitchen,
meeting rooms or open
spaces, Blonde is the ceiling
lamp that is versatile both
in terms of use and the
customisation of its finishings.**

Fantasia eclettica.

La forma trapezoidale caratterizza gli ambienti con decisione: in cucina, in sala riunioni o in open space, Blonde è la lampada a soffitto versatile nell'uso e nella personalizzazione delle finiture.



TABLE LAMPS



BLONDE pendant lamp | Gold
X9 meeting table | Elm top with Anthracite leather inlay
DIADE executive chair | P01/172 leather

Lighting & Acoustic Collection

DESIGN LIGHTING

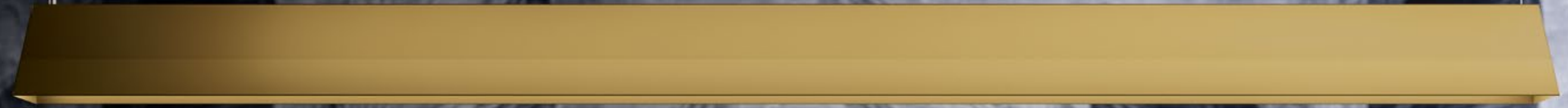

128

129





Pendant lamp

BLONDE

Pendant lamp in powder coated aluminium.
Lampada a sospensione in alluminio verniciato.

| Blonde 126 | Blonde 166 | Blonde 246 |
|------------|------------|------------|
| 67,2W LED | 90,3W LED | 136,4W LED |
| 7124 lm | 9572 lm | 14459 lm |
| 110-240V | 110-240V | 110-240V |
| 2700/3000K | 2700/3000K | 2700/3000K |
| CRI80 | CRI80 | CRI80 |
| All in one | All in one | All in one |

CE IP20   24V  MacAdam Step 3 UGR₁₉

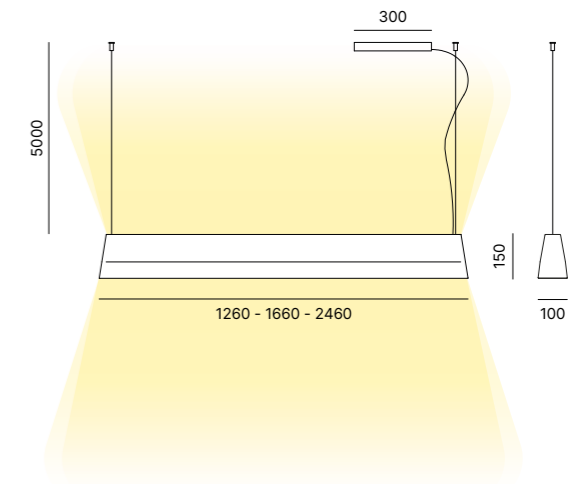

For the icon summary refer to pages 400 - 403 / Per la legenda icone vedere pp. 400 - 403

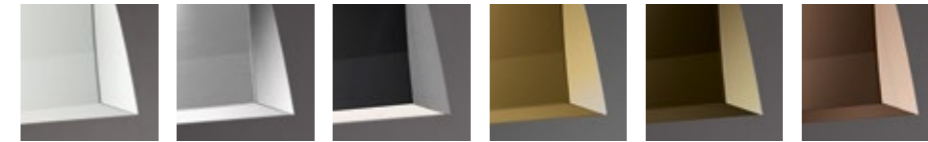
LAMP FINISH OPTIONS
FINITURE LAMPADA

Matt White

Brushed
AlluminiumBlack
Goffratino

Gold

Bronze

Corten

CEILING ROSE
ROSONE

Matt White



**Luminous arrangements.
Minimalistic design,
customisation possibilities
and adjustable intensity: CD
Led combines contemporary
aesthetics and functionality
to create large dynamic
compositions, ideal for business,
living and hospitality contexts.**

Accordi luminosi.

Design minimale, possibilità di personalizzazione e intensità regolabile: CD Led unisce estetica contemporanea e massima funzionalità per creare composizioni dinamiche di grandi dimensioni, ideali per contesti business, living e hospitality.



PENDANT LAMPS





CD LED pendant lamps | Matt Black
Z1 reception desk | Beige and White lacquered

Lighting & Acoustic Collection

136



DESIGN LIGHTING

137



Pendant lamp

CD LED

Pendant lamp with down or up light. Polycarbonate lamp diffuser with transparent or colored PMMA ring.

Lampada da sospensione a luce diretta o indiretta. Diffusore in policarbonato con anello in PMMA trasparente o colorato, struttura in metallo verniciato.

6,7W LED
110-240V
2700K
CRI90
ON-OFF | T-fase

CE IP20 LED 1250lm MacAdam Step 3

UGR₁₉

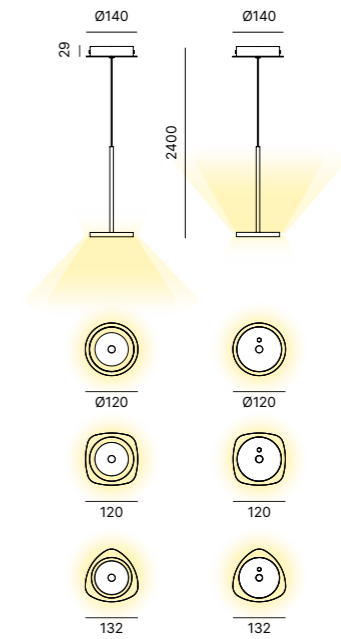

For the icon summary refer to pages 400 - 403 / Per la legenda icone vedere pp. 400 - 403

FINISH OPTIONS
FINITURE

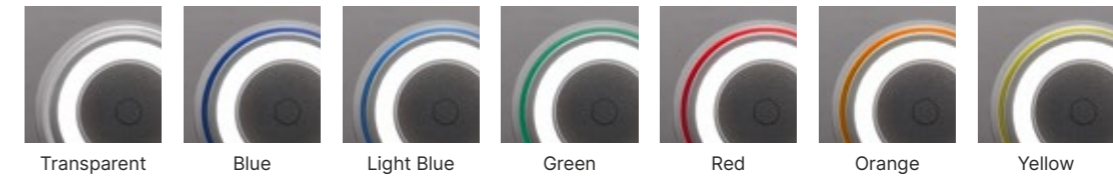

FRAME FINISH OPTIONS
FINITURE STRUTTURA



Matt Black

CD Led collection

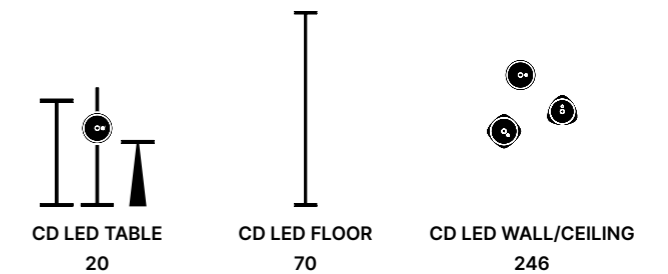



designed by Enrico Franzolini & Vicente García Jimenez

**A toast to light.
Perfect for restaurants,
clubs, wineries and hotel
lobbies, Drink is a refined
and original lighting
solution: its aluminium
upside down chalice
shape is available in five
different colours.**

Brindisi di luce.

Perfetta per ristoranti, club, enoteche e hall d'albergo,
Drink è una soluzione di illuminazione raffinata e
originale: la sua forma in alluminio a calice rovesciato è
disponibile in cinque colorazioni.



PENDANT LAMPS







Pendant lamp

DRINK

Pendant lamp in powder coated aluminium.
Lampada a sospensione in alluminio verniciato.

6,3W LED
220-240V
2700K
CRI90
T/fase | DALI/Push dimm

CE IP20 LED 45-60° 880lm MacAdam Step 3
UGR₁₉

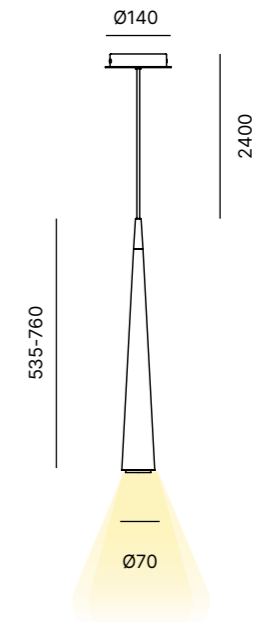

For the icon summary refer to pages 400 - 403 / Per la legenda icone vedere pp. 400 - 403

LAMP AND CEILING ROSE FINISH OPTIONS
FINITURE LAMPADA E ROSONE

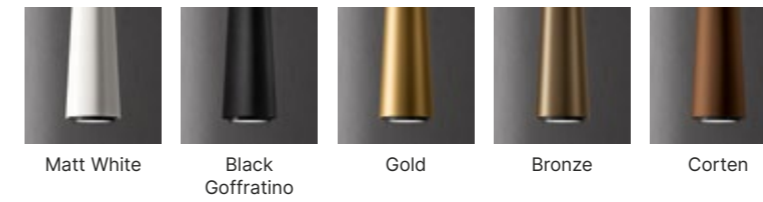

REFLECTOR FINISH OPTIONS
FINITURE RIFLETTORE



Drink collection



DRINK CEILING
252



designed by Serena Papait

Kinetic lighting.
The design of Escape embraces opposites: static and dynamic, light and shade, parallel and perpendicular. The lamp is a formal and conceptual synthesis and can be customised with different colour options for lighting shared settings.

Illuminazione cinetica.
 Il design di Escape contiene gli opposti: statico e dinamico, luce e ombra, parallelo e perpendicolare. La lampada è una sintesi formale e concettuale, personalizzabile nei colori, per illuminare ambienti condivisi.



PENDANT LAMPS





ESCAPE pendant lamps | Matt White
X3 meeting table | Oak top and White frame
CLUE design chair | White polypolyene shell with M02/584 fabric and Matt White frame

Lighting & Acoustic Collection

DESIGN LIGHTING





Pendant lamp

ESCAPE

Pendant lamp in powder coated aluminium.
Matt methacrylate diffuser.
Lampada a sospensione in alluminio verniciato.
Diffusore in metacrilato opalino.

45,2W LED
2700K
CRI90
ON-OFF | DALI/Push dimm

CE IP20   5760lm  MacAdam Step 3
UGR₁₉

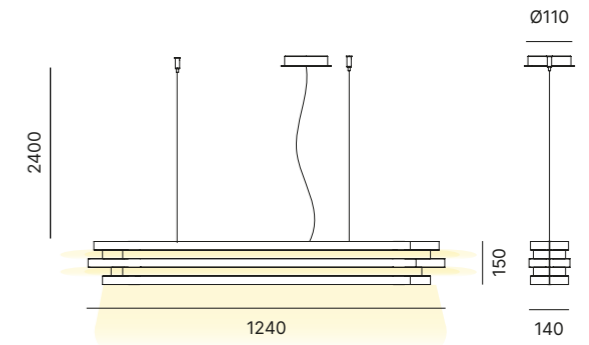

For the icon summary refer to pages 400 - 403 / Per la legenda icone vedere pp. 400 - 403

LAMP FINISH OPTIONS FINITURE LAMPADA

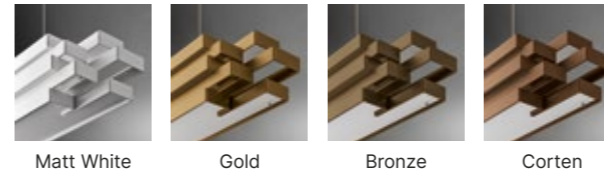

Matt White

Gold

Bronze

Corten

Escape collection



ESCAPE WALL
258



designed by Enrico Franzolini

Natural elements.
Gout draws inspiration from the shape of a water drop: the delicate blown glass diffuses a liquid light and appears crystallised in the act of falling, despite being firmly anchored to the ceiling by a painted metal rod.

Elementi naturali.

Gout prende ispirazione dalla forma di una goccia d'acqua: il vetro soffiato, delicatissimo, diffonde una luce liquida e sembra cristallizzato nell'atto di cadere, mentre è saldamente ancorato al soffitto da un'asta in metallo verniciato.



PENDANT LAMPS





GOUT pendant lamps | Glossy White and Black glass shade
Z2 reception desk | Canaletto Walnut and Brown leather



Pendant lamp

GOUT

Pendant lamp with blown glass diffuser. Powder coated metal stem and ceiling rose.
Lampada a sospensione con diffusore in vetro soffiato. Asta e rosone in metallo verniciato.

MAX 1XE27 100W
220-240V
T/fase

CE IP20 

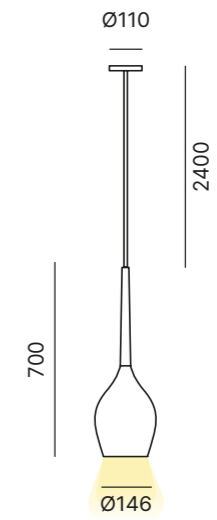

For the icon summary refer to pages 400 - 403 / Per la legenda icone vedere pp. 400 - 403

LAMP FINISH OPTIONS
FINITURE LAMPADAGlossy White
glassGlossy Black
glassCEILING ROSE
ROSONEBlack
goffratino



designed by Moreno De Giorgio

**Innate grace.
Classical and original,
Grace features a
natural linen or black
cotton shade and
makes the perfect
addition to different
settings.**

Grazia innata.
Classica e ricercata, Grace ha un paralume
in lino naturale o cotone nero e si inserisce
alla perfezione in diversi contesti.



PENDANT LAMPS



GRACE pendant lamps | Natural Linen shade
SEVEN table | Canaletto Walnut top and Bronze frame
CODE design chair | Walnut varnished solid ash wood shell and legs





Pendant lamp

GRACE

Pendant lamp with linen or cotton shade.
Lampada a sospensione con paralume in lino o cotone.

MAX 3XE27 60W
220-240V
T/fase

CE IP20 

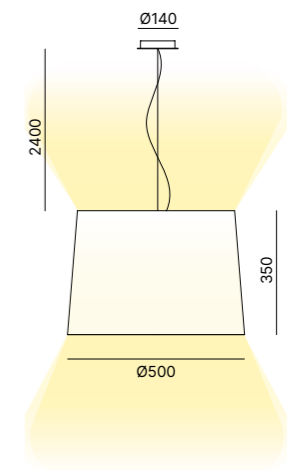

For the icon summary refer to pages 400 - 403 / Per la legenda icone vedere pp. 400 - 403

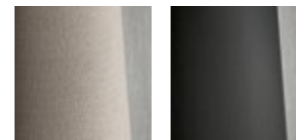
SHADE FINISH OPTIONS
FINITURE PARALUME

Natural Linen Black Cotton

CEILING ROSE
ROSONE

Black
goffratino

Grace collection

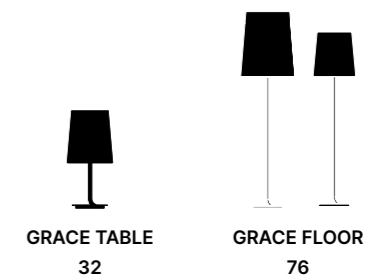

GRACE TABLE
32

GRACE FLOOR
76

HALF MOON

designed by Enrico Franzolini & Vicente García Jimenez

**Eclipse of design.
Half Moon is simple,
essential and yet timelessly
alluring: the colours of the
shade and the inner part can
be personalised, bringing
to life original lamps with a
modern look.**

Eclissi di design.

Half Moon è semplice ed essenziale, ma conserva un fascino senza tempo: i colori del paralume e dell'interno possono essere personalizzati per dare vita a lampade originali dal look moderno.



PENDANT LAMPS



HALF MOON pendant lamps | Natural Linen shade
SIX table | Noir Desir porcelain stoneware top and Umбра Grey frame
COVE design chair | B03/185 simil leather and Walnut varnished solid ash wood legs

Lighting & Acoustic Collection

DESIGN LIGHTING





Pendant lamp

HALF MOON

Pendant lamp with linen or cotton shade with white or colored inside.
 Lampada a sospensione con paralume in lino o cotone, con interno coprente bianco o colorato.

MAX 3XE27 60W
 220-240V
 T/fase

CE IP20

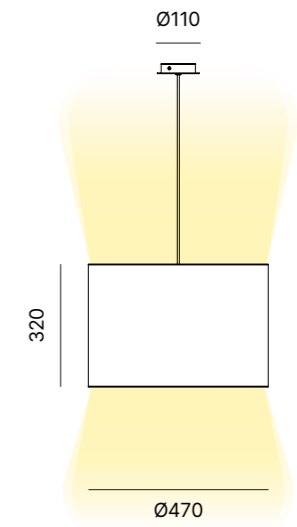

For the icon summary refer to pages 400 - 403 / Per la legenda icone vedere pp. 400 - 403

SHADE FINISH OPTIONS
 FINITURE PARALUME



Black Cotton White inside Black Cotton Yellow inside Black Cotton Orange inside Black Cotton Fuchsia inside Natural Linen White inside Natural Linen Yellow inside Natural Linen Orange inside Natural Linen Fuchsia inside

FRAME FINISH OPTIONS
 FINITURE STRUTTURA



Black Goffratino Gold Bronze Corten

Half Moon collection

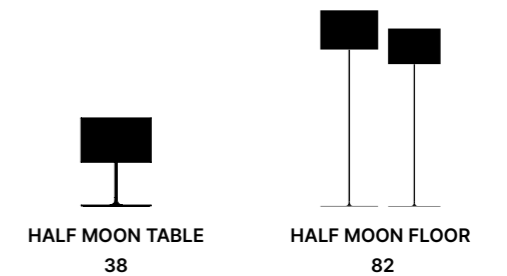



designed by David Dolcini

**Enlightened apparition.
Mirage is the lighting solution
suitable for elegant and
chic settings: the shade
is the same colour as the
ceiling rose and features a
chromed external finishing, to
amplify light and its exquisite
reflections.**

Apparizione lucente.

Mirage è la soluzione di illuminazione adatta a contesti eleganti e chic: il paralume, in tinta col rosone, ha la finitura esterna cromata per amplificare la luce e i suoi riflessi preziosi.



PENDANT LAMPS







Pendant lamp

MIRAGE

Pendant lamp in powder coated metal, ceiling rose in matching finish.
Lampada a sospensione in metallo verniciato con rosone in tinta.

9,6W LED
220-240V
2700K
CRI80
T/fase

CE IP20   800lm UGR₁₉

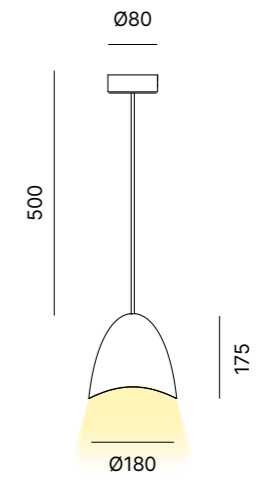

For the icon summary refer to pages 400 - 403 / Per la legenda icone vedere pp. 400 - 403

LAMP FINISH OPTIONS
FINITURE LAMPADA

White

Polished
ChromePolished
CopperPolished
GoldCEILING ROSE
ROSONE

White

Polished
ChromePolished
CopperPolished
Gold



Style evolution.
The result of extensive technological research, the fibreglass lampshade of Ola filters light in a unique way through shapes and colours, for material lighting laden with sensations.

Stile in divenire.
Frutto di una lunga ricerca tecnologica, il paralume in fibra di vetro di Ola filtra la luce in modo unico attraverso forme e colori, per un'illuminazione materica ricca di sensazioni.



PENDANT LAMPS



OLA pendant lamps | Gold fibreglass shade
TWO table | Eucaliptus top and Bronze frame
CITY DÉCO design chair | E04/487 fabric and Bronze frame





Pendant lamp

OLA

Pendant lamp with fibreglass shade.
Lampada a sospensione con paralume in fibra di vetro.

MAX 3XE27 60W
220-240V
T/fase

CE IP20 

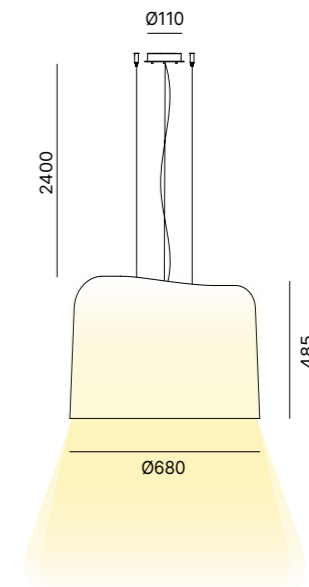

For the icon summary refer to pages 400 - 403 / Per la legenda icone vedere pp. 400 - 403

SHADE FINISH OPTIONS
FINITURE PARALUME

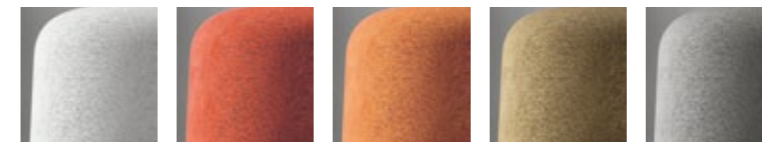

White fibreglass Red fibreglass Orange fibreglass Gold fibreglass Silver fibreglass

CEILING ROSE
ROSONE



Black goffratino White

Ola collection

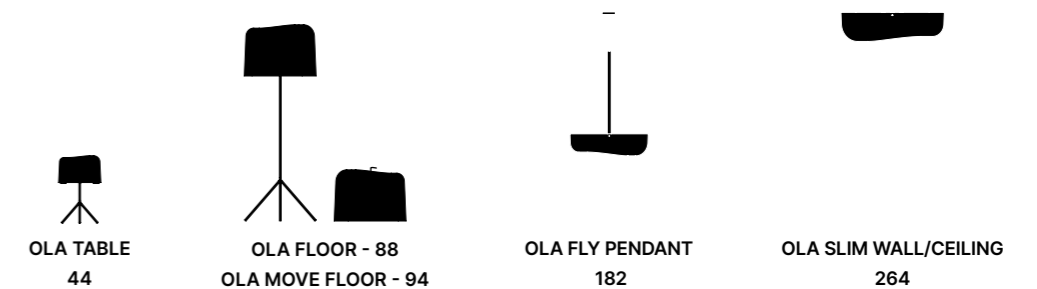



**Dreamy forms.
Ideal for business and
hospitality settings, Ola Fly
reinterprets the tonalities
of light through the colours
of its fibreglass shade and
is available with white, red,
orange, gold and silver
finishings.**

Forme sognanti.
Ideale per ambienti business e hospitality, Ola Fly reinterpreta le
tonalità della luce attraverso i colori del suo paralume in fibra di
vetro, nelle finiture bianco, rosso, arancio, oro e argento.



PENDANT LAMPS





Pendant lamp

Pendant lamp with fibreglass shade.
Lampada a sospensione con paralume in fibra di vetro.

MAX 3XE27 60W
220-240V
T/fase

CE IP20 

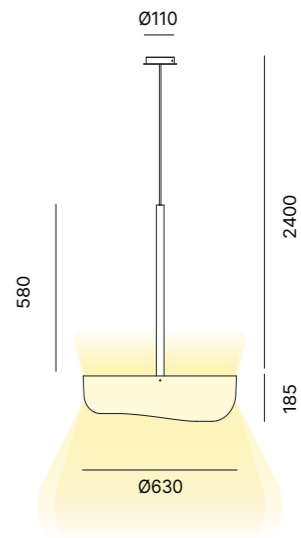

For the icon summary refer to pages 400 - 403 / Per la legenda icone vedere pp. 400 - 403

SHADE FINISH OPTIONS
FINITURE PARALUME

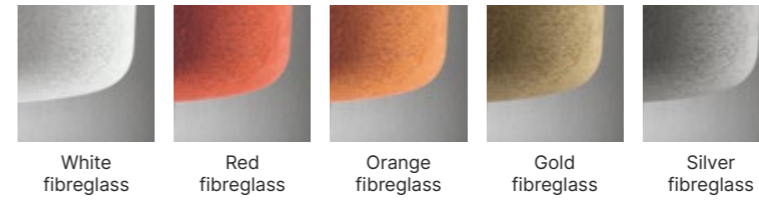

CEILING ROSE
ROSONE



Ola collection

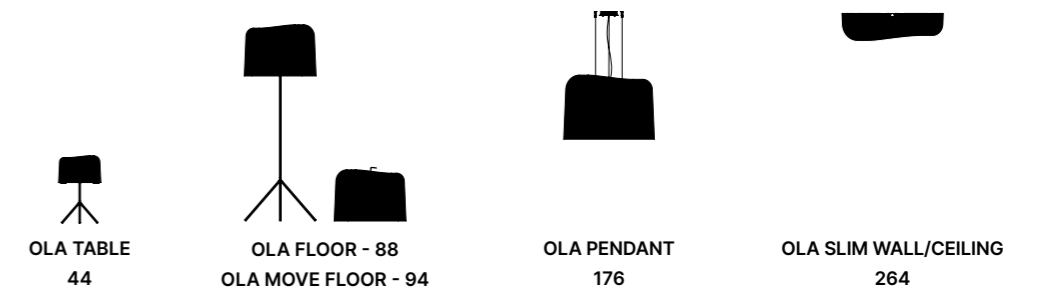

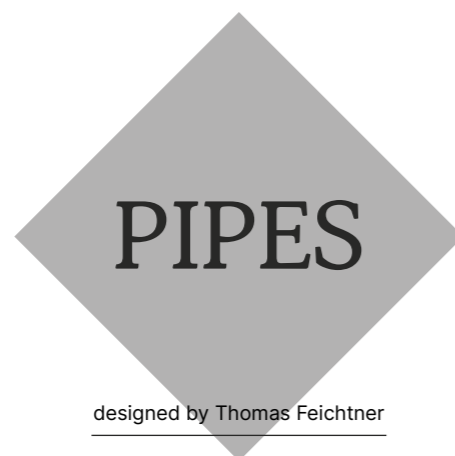

Gleaming chrome.
Pipes features a tubular structure,
consisting of curved and woven
aluminium, available in four
tonalities: white, bronze, gold
and corten. It reigns supreme in
dining rooms, reception areas and
convivial settings.

Chioma brillante.

Pipes ha una struttura tubolare, formata da alluminio curvato e intrecciato, disponibile in quattro tonalità: bianco, bronzo, oro e corten. È la protagonista di sale da pranzo, aree reception e luoghi conviviali.



PENDANT LAMPS







Pendant lamp

PIPES

Pendant lamp made by powder coated aluminium pipes.
Lampada a sospensione composta da tubi in alluminio verniciati.

17W LED
2700K
CRI80
DALI/Push dimm

CE IP20   1400lm UGR₁₉

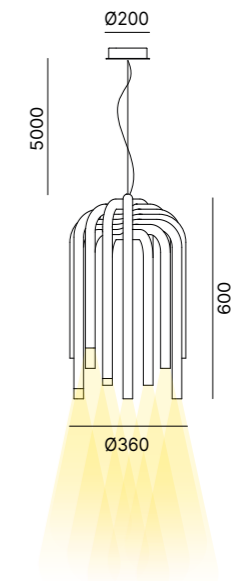

For the icon summary refer to pages 400 - 403 / Per la legenda icone vedere pp. 400 - 403

SHADE FINISH OPTIONS FINITURE PARALUME



Matt White

Gold

Bronze

Corten

CEILING ROSE ROSONE



Matt White



**Suspended galaxy.
Light propagates in Planet
from the curved aluminium
circle, available in 3 diameter
sizes and different finishings,
resulting in the perfect
lighting for boardroom and
meeting interiors.**

**Galassia sospesa.
La luce di Planet si propaga dal cerchio in alluminio calandrato,
disponibile in 3 misure di diametro e in diverse finiture:
l'illuminazione perfetta per spazi di rappresentanza e di incontro.**



PENDANT LAMPS





196

PLANET pendant lamps | Gold
Z1 reception desk | Umbra Grey and Silk Grey lacquered

The LED lighting, which is both direct and indirect, resides in the circular profile, and it is equipped with an intensity-adjustable diffuser.

L'illuminazione a led, diretta e indiretta, risiede nel profilo circolare, il quale è dotato di diffusore regolabile in intensità.



197

PLANET pendant lamps | Matt White
CELSIUS chair | E02/445 fabric and Chrome legs
FIVE table | White top and frame

Lighting & Acoustic Collection

DESIGN LIGHTING

198

199





Pendant lamp

PLANET

Pendant lamp in powder coated aluminium.
Lampada a sospensione in alluminio verniciato.

| Planet 70 | Planet 90 | Planet 110 |
|---------------------|---------------------|---------------------|
| 2700K | 2700K | 2700K |
| CRI90 | CRI90 | CRI90 |
| ON-OFF All in one | ON-OFF All in one | ON-OFF All in one |
| Down light | Down light | Down light |
| 28W LED | 35W LED | 46W LED |
| 4548 lm | 5880 lm | 7696lm |
| Up/Down light | Up/Down light | Up/Down light |
| 54W LED | 67W LED | 88W LED |
| 9096 lm | 11760lm | 15392lm |

CE IP20    MacAdam Step 3

For the icon summary refer to pages 400 - 403 / Per la legenda icone vedere pp. 400 - 403

SHADE FINISH OPTIONS
FINITURE PARALUME

Matt White

Gold

Bronze

Corten

CEILING ROSE
ROSONE

Matt White

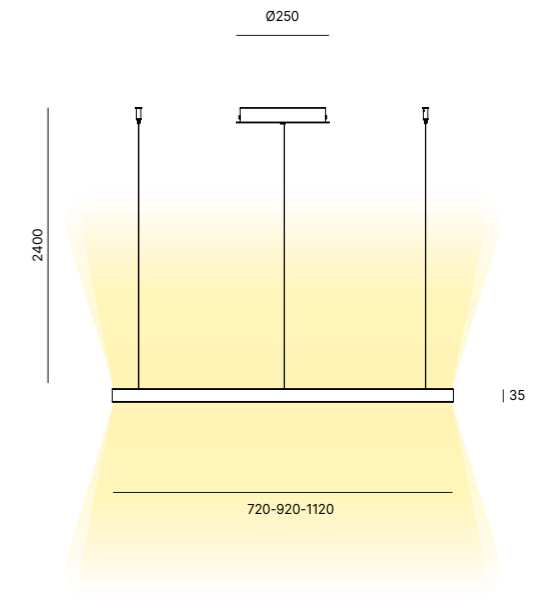



designed by Enrico Franzolini

Cut of light.
Slice features a clean-cut and decisive aluminium profile: it diffuses punctual light and can be articulated in compositions consisting of several items or a single lamp, for lighting in living, hospitality and business settings.

Taglio di luce.

Slice ha un profilo in alluminio netto e deciso: diffonde una luce puntuale e si può articolare in composizioni a più pezzi o con lampada singola, per illuminare spazi living, hospitality e business.



PENDANT LAMPS



SLICE pendant lamps | Gold





Pendant lamp

SLICE

Pendant lamp in powder coated aluminium.
Lampada a sospensione in alluminio verniciato.

6,3W LED
220-240V
2700K
CRI90
T/fase | DALI/Push dimm

CE IP20 LED 45-60° 880lm MacAdam Step 3
UGR₁₉

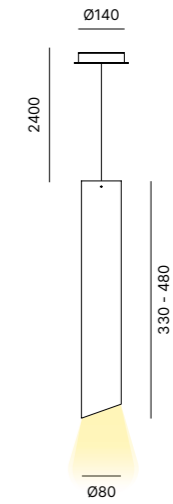

For the icon summary refer to pages 400 - 403 / Per la legenda icone vedere pp. 400 - 403

LAMP FINISH OPTIONS
FINITURE LAMPADA



CEILING ROSE
ROSONE

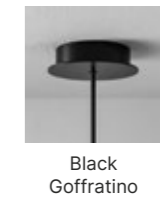

REFLECTOR FINISH OPTIONS
FINITURE RIFLETTORE



Slice collection

SLICE WALL/CEILING
276

STARLIGHT

designed by Serena Papait

**Slender elegance.
Starlight is a veritable
geometric sculpture with
soft and indirect led lighting.
It creates plays of shadows
and lights and is suitable
for enhancing a suffused
ambience in refined settings.**

Esile eleganza.

Starlight è una vera e propria scultura geometrica con illuminazione a led soft e indiretta. Crea giochi di ombre e riflessi, adatti a suggerire atmosfere soffuse per ambienti ricercati.



PENDANT LAMPS





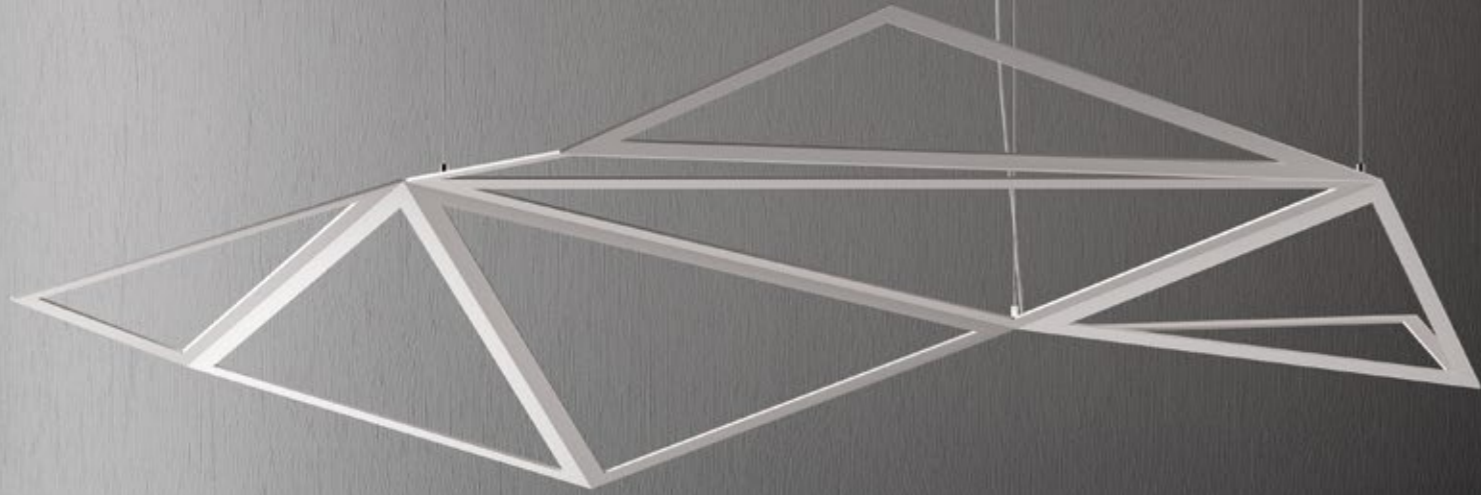

Pendant lamp

STARLIGHT

Pendant lamp in powder coated aluminium, up light.
Lampada a sospensione in alluminio verniciato, luce indiretta.

| Starlight | Starlight Giant |
|-------------|-----------------|
| 22W LED | 47W LED |
| 2700 lm | 5400 lm |
| 2700K | 2700K |
| CRI90 | CRI90 |
| DALI/Dimmer | DALI/Dimmer |

CE IP20 LED UGR₁₉

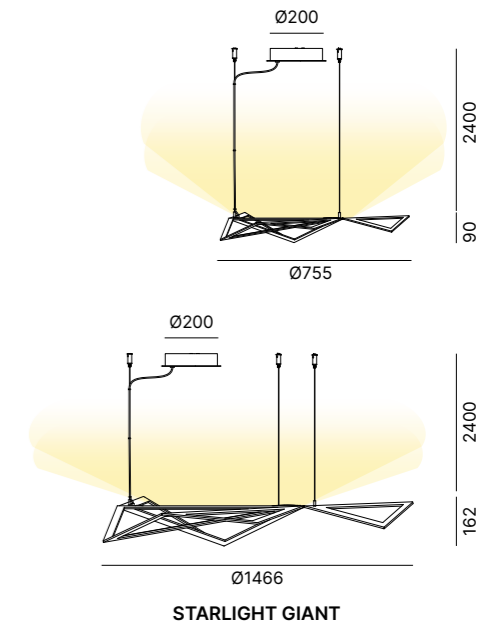

For the icon summary refer to pages 400 - 403 / Per la legenda icone vedere pp. 400 - 403

LAMP FINISH OPTIONS
FINITURE LAMPADA

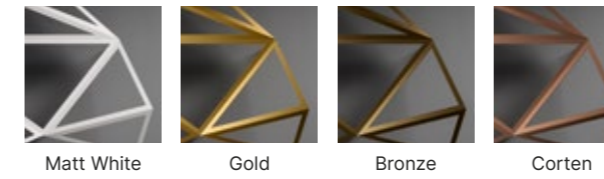

CEILING ROSE
ROSONE



Matt White

Starlight collection

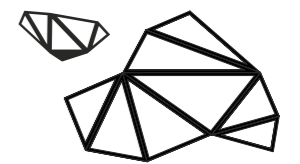

STARLIGHT WALL
282

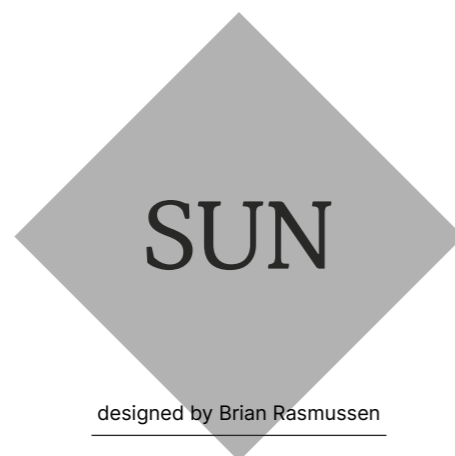

**Solar creativity.
Sun multiplies, fragments
and adds dynamism to light
through the eccentric woven
fabric shade, customisable in
three tonalities. The suspended
version is available in two
sizes, adding character to
contemporary settings.**

Creatività solare.

Sun moltiplica, frammenta e rende dinamica la luce attraverso l'eccentrico paralume in tessuto lavorato, personalizzabile in tre tonalità. La versione a sospensione è disponibile in due dimensioni, per dare carattere ad ambienti contemporanei.



PENDANT LAMPS



SUN pendant lamps | Black fabric shade
X9 meeting table | Elm top with Anthracite leather inlay, Umbra Grey frame
DIADE executive chair | P01/172 leather





Pendant lamp

SUN

Pendant lamp with fabric shade.
Lampada a sospensione con paralume in tessuto.

| Sun 50 | Sun 75 |
|----------------|---------------|
| MAX 1XE27 100W | MAX 3XE27 60W |
| 220-240V | 220-240V |
| T/fase | T/fase |

CE IP20 

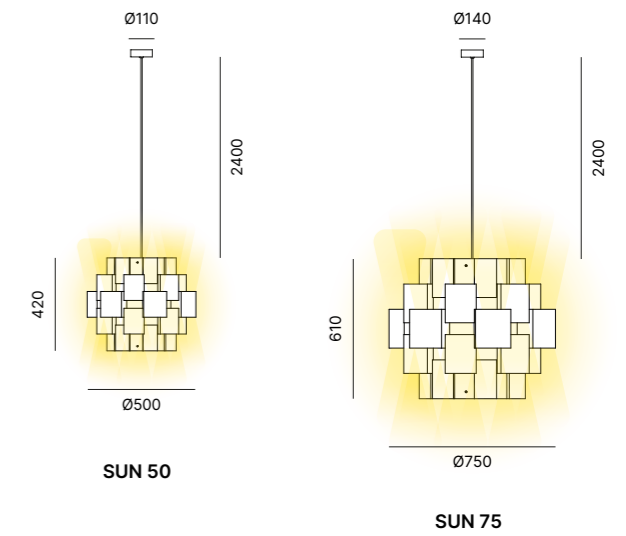

For the icon summary refer to pages 400 - 403 / Per la legenda icone vedere pp. 400 - 403

SHADE FINISH OPTIONS
FINITURE PARALUME



White fabric Black fabric Red fabric

CEILING ROSE
ROSONE



Matt White

Sun collection

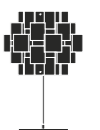

SUN TABLE
50



**Diffused allure.
Sveva is the queen in any
setting, delivering pleasant
and diffused light in business
and hospitality interiors
while seamlessly matching
different styles thanks to
customisation options for its
finishings.**

**Charme diffuso.
Sveva è la regina di ogni spazio: getta una luce garbata e diffusa
su ambienti business e hospitality e si intona a diversi contesti
grazie alla possibilità di personalizzare le finiture.**



PENDANT LAMPS







Pendant lamp

SVEVA

Pendant lamp in powder coated aluminium.

Matt methacrylate diffuser.

Lampada a sospensione in alluminio verniciato.



Diffusore in metacrilato opalino.

40W LED

3000K

CRI90

ON-OFF | All in one

CE IP20   24V 5922lm  MacAdam Step 3

UGR₁₉

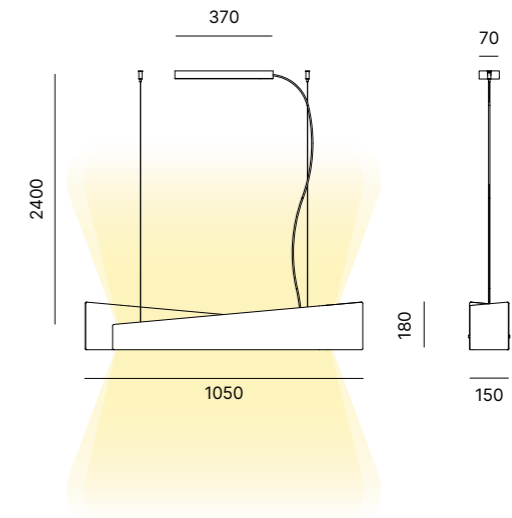

For the icon summary refer to pages 400 - 403 / Per la legenda icone vedere pp. 400 - 403

LAMP FINISH OPTIONS
FINITURE LAMPADA

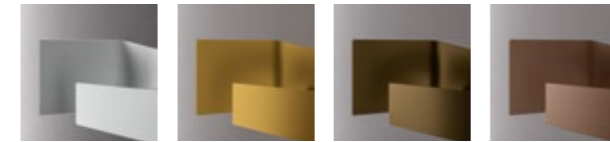

Matt White

Gold

Bronze

Corten

DIFFUSER
DIFFUSORE



PMMA

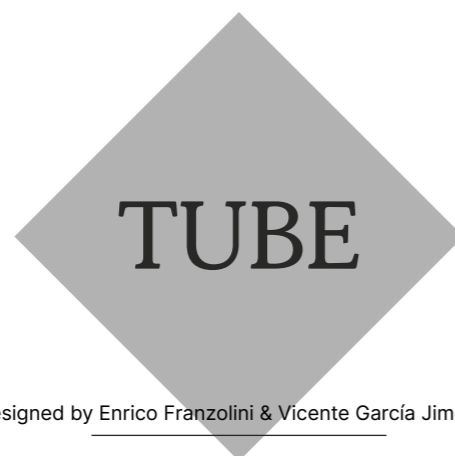

designed by Enrico Franzolini & Vicente García Jimenez

Winning simplicity.
Tube is an equation that resolves all project design and aesthetic requirements: 80 mm diameter, 2 available lengths and a choice of 5 finishings and infinite modulation options, with one or more lamps.

Semplicità vincente.

Tube è un'equazione che risolve ogni esigenza progettuale ed estetica: 80 mm di diametro, 2 lunghezze disponibili, 5 finiture tra cui scegliere e infinite possibilità di modulazione, con lampada singola o più lampade.



PENDANT LAMPS







Pendant lamp

TUBE

Pendant lamp in powder coated aluminium.
Lampada a sospensione in alluminio verniciato.

6,3W LED
220-240V
2700K
CRI90
T/fase | DALI/Push dimm

CE IP20 LED 45-60° 880lm MacAdam Step 3 UGR₁₉

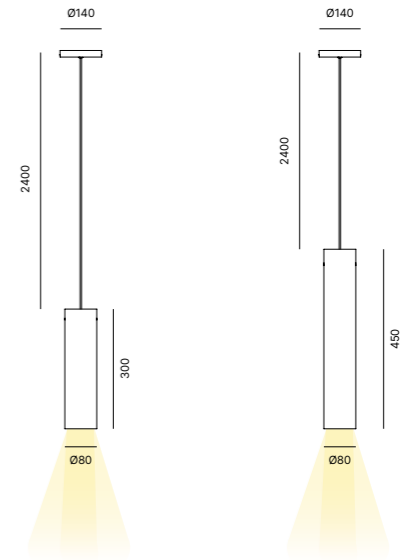

For the icon summary refer to pages 400 - 403 / Per la legenda icone vedere pp. 400 - 403

SHADE FINISH OPTIONS
FINITURE PARALUME

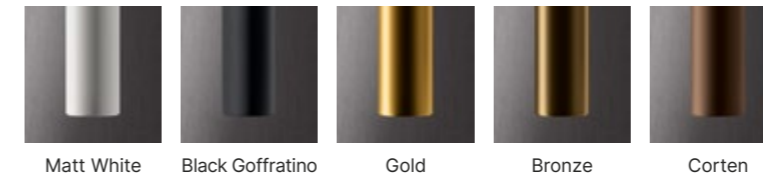

CEILING ROSE
ROSONE

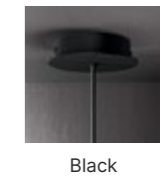

REFLECTOR FINISH OPTIONS
FINITURE RIFLETTORE



Tube collection



TUBE MICRO PENDANT
232

TUBE WALL/CEILING
288

TUBE MICRO

designed by Quadrifoglio Group

Slender soul.
Tube Micro illuminates residential and professional settings with versatile compositions: cascades, sprinkles, duets and monologues of light inspired by lightness and elegance. The punctual light showcases any furnishing detail.

Anima sottile.

Tube Micro illumina ambienti residenziali e professionali con composizioni versatili: cascate, piogge, duetti e monologhi di luce all'insegna della leggerezza e dell'eleganza. La luce puntuale rende protagonisti i dettagli di ogni arredo.



TABLE LAMPS



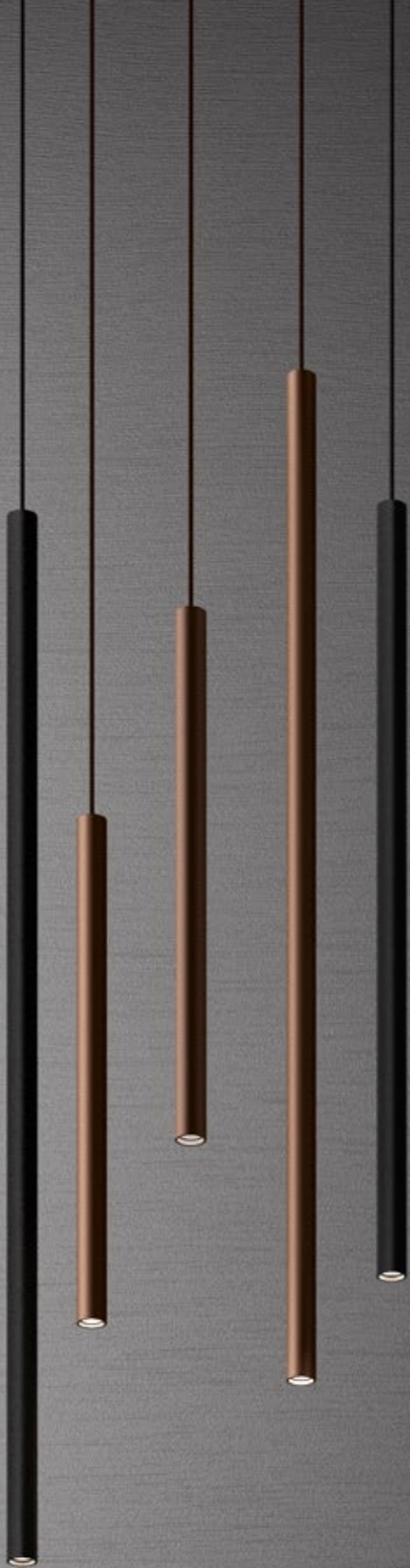

Pendant lamp

TUBE MICRO

Pendant lamp in powder coated aluminium.
Lampada a sospensione in alluminio verniciato.

1,5W LED
2700K
CRI90
ON-OFF

CE IP20 LED 18° 150lm MacAdam Step 6 UGR₁₉

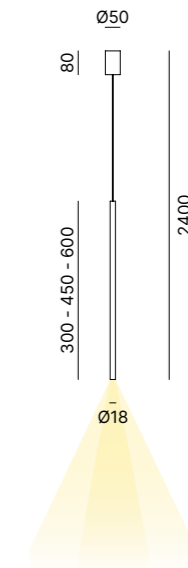

For the icon summary refer to pages 400 - 403 / Per la legenda icone vedere pp. 400 - 403

SHADE FINISH OPTIONS
FINITURE PARALUME



Tube collection

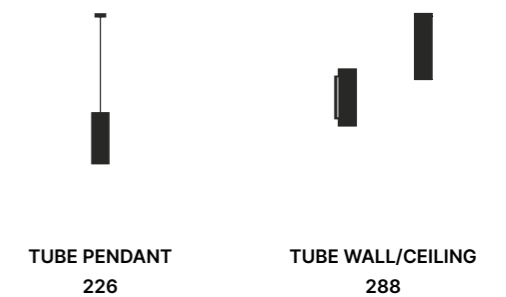

Wall/Ceiling Lamps

Decorative Lighting

Lighting & Acoustic Collection

Wall/Ceiling lamps

DESIGN LIGHTING



ALALUNGA

ALALUNGA WALL - 240



CD LED

CD LED WALL - 246



DRINK

DRINK CEILING - 252



ESCAPE

ESCAPE WALL - 258



OLA SLIM

OLA SLIM WALL/CEILING - 264



SHADOW

SHADOW WALL - 270



SLICE

SLICE CEILING - 276

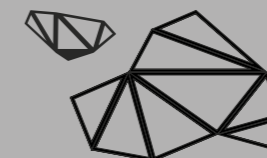

STARLIGHT

STARLIGHT WALL - 282



TUBE

TUBE WALL/CEILING - 288



TUPLA

TUPLA WALL - 296



TURN ME!

TURN ME! WALL - 302

ALALUNGA

designed by Enrico Franzolini

**The beat of a wing.
Alalunga is a wall-hung painted metal appliqué available in two sizes and four deluxe finishings. Its elegant and luminous presence enhances contemporary and exclusive settings with delicate lighting.**

Battito d'ali.

Alalunga è un'applique da parete in metallo verniciato, disponibile in due dimensioni e quattro finiture deluxe. La sua presenza, leggiadra e luminosa, valorizza ambienti contemporanei ed esclusivi con un'illuminazione leggera.

WALL/CEILING LAMPS



ALALUNGA wall lamp | Bronze
BLONDE pendant lamp | Bronze
NINE table | Ebony top and Umbra Grey legs

Lighting & Acoustic Collection



242

243

DESIGN LIGHTING



Wall lamp

ALALUNGA

Wall lamp in powder coated metal.
Lampada a parete in metallo verniciato.

| Alalunga Mini | Alalunga |
|---------------|-------------------------|
| 9,2W LED | 10,9W LED |
| 720 lm | 1300 lm |
| 220-240V | 110-240V |
| 2700K | 2700K |
| CRI90 | CRI90 |
| T/fase | T/fase DALI/Push dimm |

CE IP20  UGR₁₉

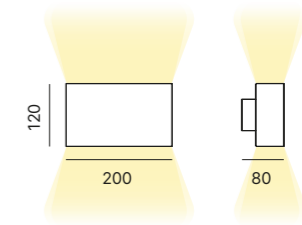

ALALUNGA MINI

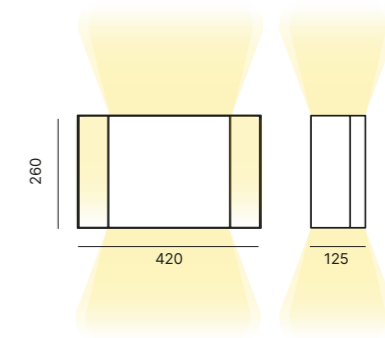

ALALUNGA

For the icon summary refer to pages 400 - 403 / Per la legenda icone vedere pp. 400 - 403

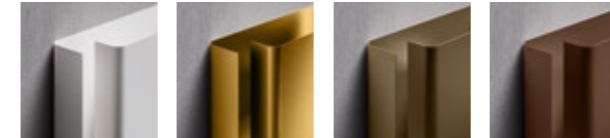
SHADE FINISH OPTIONS
FINITURE PARALUME

Matt White

Gold

Bronze

Corten



designed by Moreno De Giorgio

**Intense constellations.
Refined and shaded wall
lighting: CD Led in the appliqué
version is available in numerous
colours and three shapes,
modulable in single or multiple
compositions that are always
new and surprising.**

Costellazioni intense.

Un'illuminazione a parete raffinata e sfumata: CD Led in versione applique è disponibile in numerosi colori e in tre forme, modulabili in composizioni, singole o plurime, sempre nuove e sorprendenti.

246



WALL/CEILING LAMPS



247

CD LED wall lamps | Matt Black
CITY LOUNGE armchair | B03/185 simil leather and Black base
MELBOURNE side table | Umbra Grey lacquered top and Oak varnished solid ash wood legs



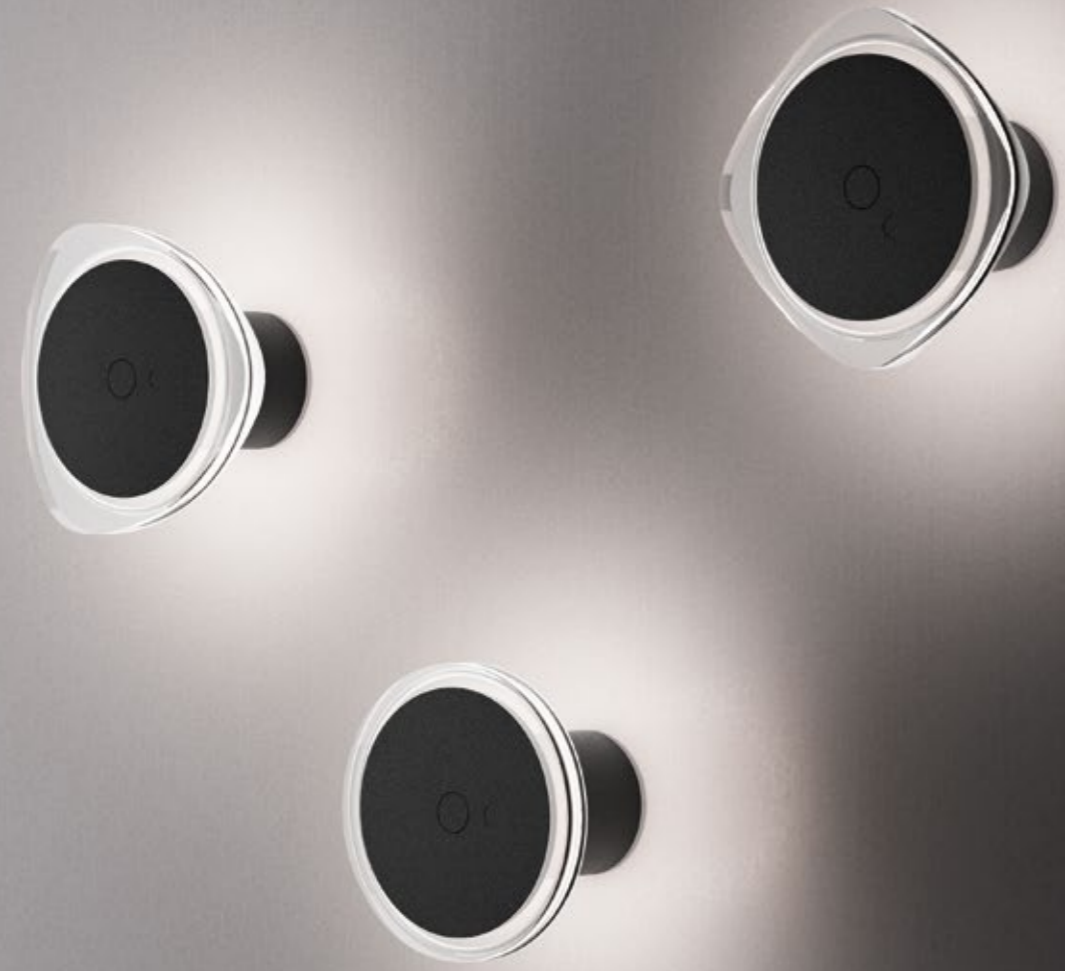

Wall lamp

CD LED

Polycarbonate lamp diffuser with transparent or colored PMMA ring, powder coated metal frame.
 Diffusore in policarbonato con anello in PMMA trasparente o colorato, struttura in metallo verniciato.

8,4W LED
 220-240V
 2700K
 CRI90
 ON-OFF | T/fase

CE IP20 LED 24V 1250lm MacAdam Step 3
 UGR₁₉

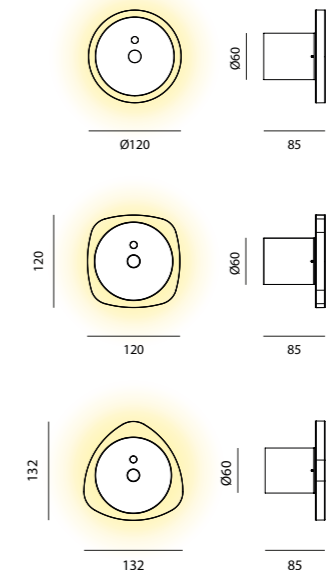

For the icon summary refer to pages 400 - 403 / Per la legenda icone vedere pp. 400 - 403

FINISH OPTIONS
 FINITURE

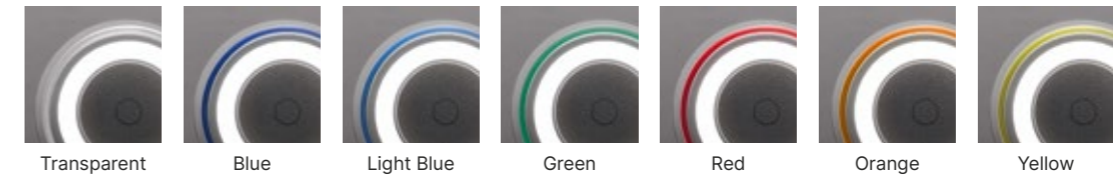

FRAME FINISH OPTIONS
 FINITURE STRUTTURA



Matt Black

CD Led collection

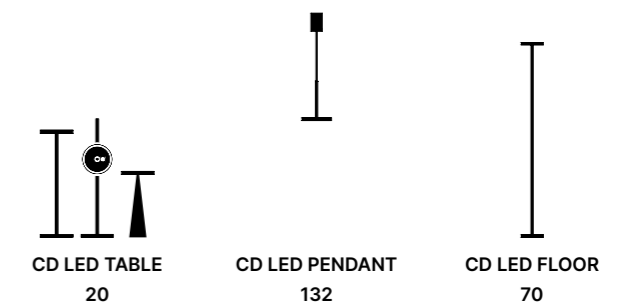



designed by Enrico Franzolini & Vicente García Jimenez

**Convivial lighting.
Drink is the perfect pendant
lamp for restaurants, hotels,
wineries, clubs and other
shared spaces. The aluminium
structure is orientable and
adjustable according to
needs, for lighting tables and
seating.**

illuminazione conviviale.

Drink è la lampada a sospensione perfetta per ristoranti, hotel, enoteche, club e altri spazi di condivisione. La struttura in alluminio è orientabile e regolabile a seconda delle esigenze, per illuminare tavoli e sedute.



WALL/CEILING LAMPS









Ceiling lamp

DRINK

Ceiling lamp in powder coated aluminium.
Lampada a soffitto in alluminio verniciato.

6,3W LED
220-240V
2700K
CRI90
T/fase | DALI/Push dimm

CE IP20   880lm  MacAdam Step 3
UGR₁₉

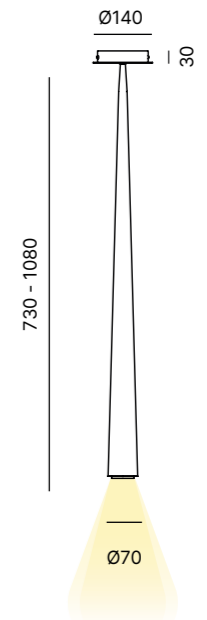

For the icon summary refer to pages 400 - 403 / Per la legenda icone vedere pp. 400 - 403

LAMP AND CEILING ROSE FINISH OPTIONS
FINITURE LAMPADA E ROSONE



Matt White

Black
Goffratino

Gold

Bronze

Corten

REFLECTOR FINISH OPTIONS
FINITURE RIFLETTORE

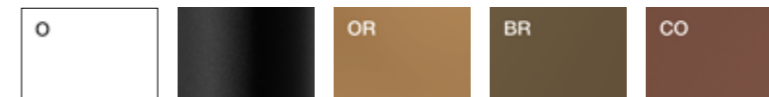

Matt White

Black Goffratino

Gold

Bronze

Corten

Drink collection



DRINK PENDANT
140



A play of planes.
Escape is available in different colours and three sizes, from big to small. Its light glides from one level to another, creating a dynamic and vibrant effect, ideal for lighting in residential and hospitality settings.

Gioco di piani.
 Escape è disponibile in diversi colori e in tre dimensioni, dalla più compatta alla più estesa: la sua luce scivola da un livello all'altro creando un effetto dinamico e vibrante, ideale per illuminare ambienti residenziali e spazi ricettivi.

 WALL/CEILING LAMPS





ESCAPE wall lamp | Matt White
CITY LOUNGE armchair and ottoman | E04/490 fabric and Black base





Wall lamp

ESCAPE

Wall lamp in powder coated aluminium.
 Matt methacrylate diffuser.
 Lampada a parete in alluminio verniciato. Diffusore in metacrilato opalino.

| Escape Cube | Escape 50 | Escape 80 |
|-------------|-----------|-----------|
| 8,7W LED | 12,5W LED | 22,6W LED |
| 800 lm | 1440 lm | 2880 lm |
| 220-240V | 220-240V | 220-240V |
| 2700K | 2700K | 2700K |
| CRI80 | CRI90 | CRI90 |
| T/fase | T/fase | T/fase |

CE IP20 LED MacAdam Step 3 UGR₁₉

For the icon summary refer to pages 400 - 403 / Per la legenda icone vedere pp. 400 - 403

LAMP FINISH OPTIONS
 FINITURE LAMPADA

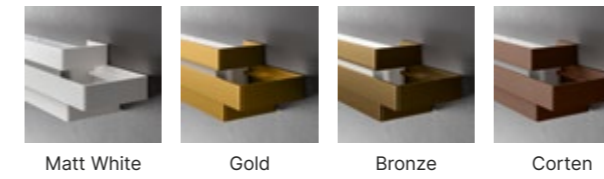

Matt White Gold Bronze Corten

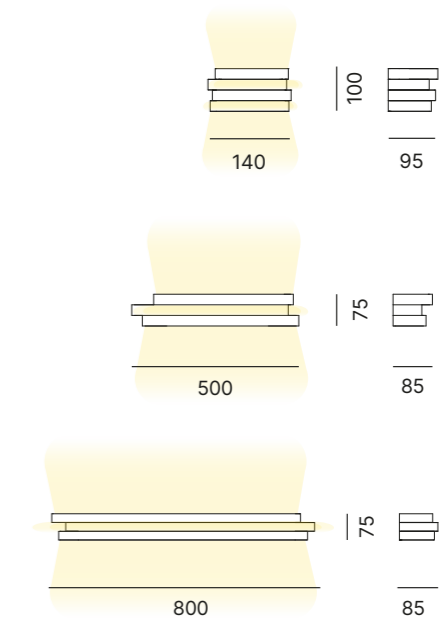

Escape collection

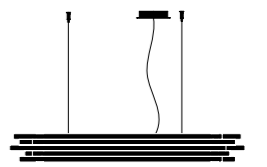

ESCAPE PENDANT
 146

OLA SLIM

designed by Enrico Franzolini

**Lunar Ambience.
Light becomes tactile
perception thanks to the
fibreglass shade filter of
Ola Slim, the wall lamp
that evokes suggestions
from other worlds, in any
interior.**

Atmosfere lunari.
La luce si fa percezione tattile grazie al filtro del paralume in
fibra di vetro di Ola Slim, la lampada a parete capace di evocare
suggerimenti di altri mondi in ogni ambiente.

WALL/CEILING LAMPS



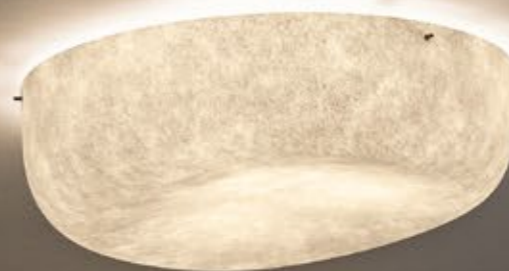

OLA SLIM wall/ceiling lamps | White fibreglass shade
AVANA composable sofa | D04/387 fabric and Umbra Grey legs
MIAMI side table and pot | Emperador Lucido porcelain stoneware top and Bronze frame



Wall/Ceiling lamp

OLA SLIM

Wall/Ceiling lamp with fibreglass shade.
Lampada a parete/soffitto con paralume in fibra di vetro.

MAX 3XE27 60W
220-240V
T/fase

CE IP20 ⚡

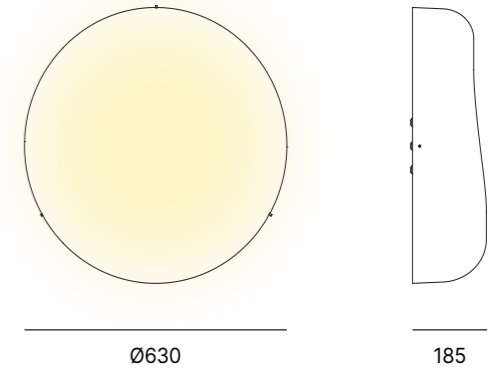

For the icon summary refer to pages 400 - 403 / Per la legenda icone vedere pp. 400 - 403

SHADE FINISH OPTIONS
FINITURE PARALUME



Ola collection

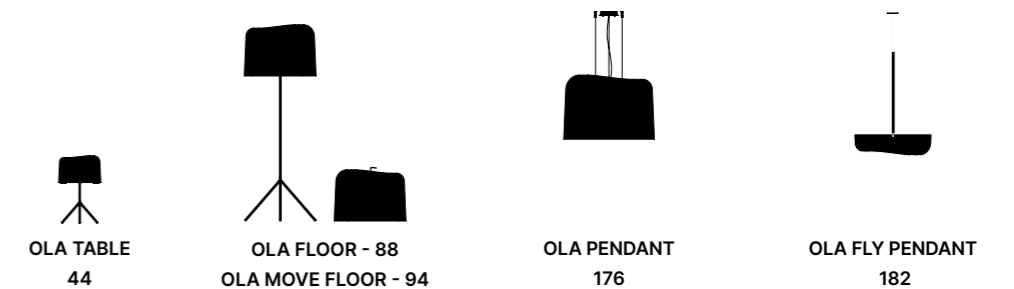

OLA TABLE
44

OLA FLOOR - 88
OLA MOVE FLOOR - 94

OLA PENDANT
176

OLA FLY PENDANT
182



**Shadow inclinations.
Shadow shields and
unleashes light according to
need, thanks to the orientable
diffuser and dimmer device
for adjusting intensity. Light
and shade coexist in an ever-
active balance.**

**Inclinazioni d'ombra.
Shadow schermo e libera la luce a seconda delle esigenze
grazie al diffusore orientabile e al dispositivo dimmer per
regolare l'intensità. Nel suo design luce e ombra convivono
in un equilibrio sempre attivo.**

WALL/CEILING LAMPS





272

273

SHADOW wall lamps | Gold
ARTE sofa | E04/493 fabric

Wall lamp

SHADOW

Wall lamp in powder coated metal.
Lampada a parete in metallo verniciato.

| Shadow 33 | Shadow 63 |
|-----------|-----------|
| 17W LED | 25,5W LED |
| 1600 lm | 2400 lm |
| 220-240V | 220-240V |
| 2700K | 2700K |
| CRI80 | CRI80 |
| T/fase | T/fase |

CE IP20  UGR₁₉

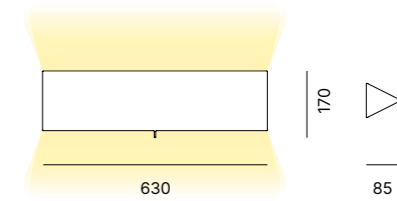
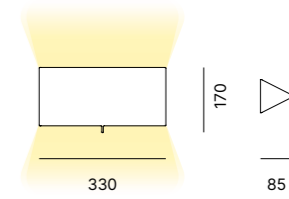

For the icon summary refer to pages 400 - 403 / Per la legenda icone vedere pp. 400 - 403

SHADE FINISH OPTIONS
FINITURE PARALUME

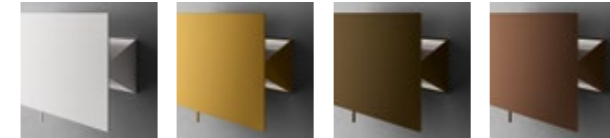

Matt White

Gold

Bronze

Corten



designed by Enrico Franzolini & Vicente García Jimenez

**Decisive character.
Cylindrical shape and direct
light: Slice is a lamp with
a decisive personality and
is fitted directly onto the
ceiling without a rose, ideal
for modern settings with an
minimalistic style.**

Carattere deciso.

Forma cilindrica e luce diretta: Slice è una lampada dalla personalità risoluta, si applica direttamente al soffitto senza l'ausilio di un rosone ed è ideale per contesti dallo stile moderno e minimal.





278

SLICE ceiling lamps | Black Goffratino lamp with Gold reflector
 LIBRERIA bookshelves | Umbra Grey Jacqué
 CLEOPAS armchair and ottoman | E03/463 fabric and Umbra Grey base

The diagonal cut of light in Slice provides lighting that is punctual and pleasant in interiors. The lamp is available in white, embossed black, gold, bronze and corten, to match different styles.

Il taglio diagonale della luce di Slice permette di illuminare gli ambienti in modo puntuale e piacevole. La lampada è disponibile in bianco, nero goffratino, oro, bronzo e corten, per intonarsi a stili diversi.



279

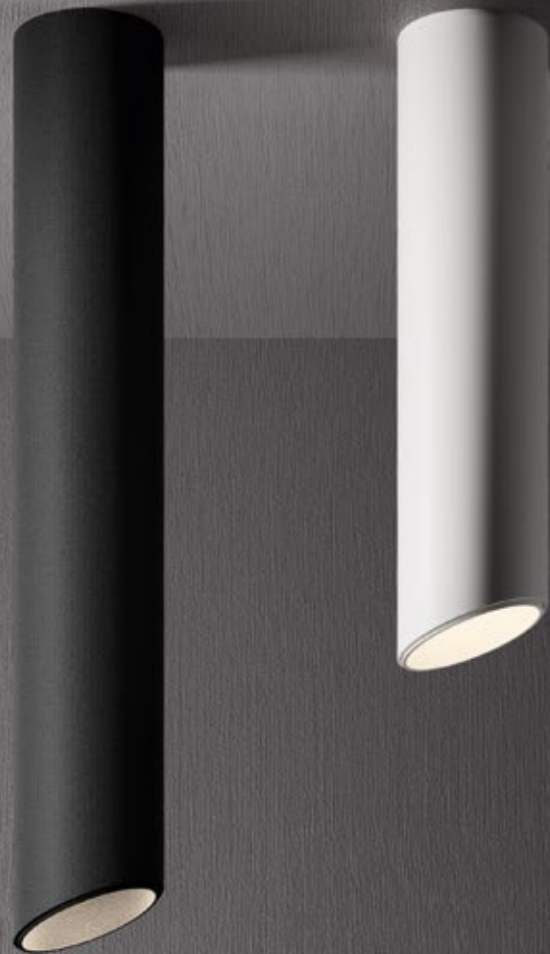

Ceiling lamp

SLICE

Ceiling lamp in powder coated aluminium.
Lampada a soffitto in alluminio verniciato.

6,3W LED
220-240V
2700K
CRI90
T/fase | DALI/Push dimm

CE IP20   880lm  MacAdam Step 3
UGR₁₉

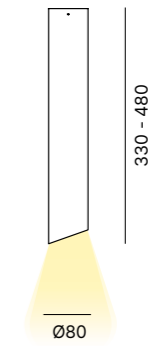

For the icon summary refer to pages 400 - 403 / Per la legenda icone vedere pp. 400 - 403

LAMP FINISH OPTIONS
FINITURE LAMPADA

Matt White

Black
Goffratino

Gold

Bronze

Corten

REFLECTOR FINISH OPTIONS
FINITURE RIFLETTORE

Matt White

Black Goffratino

Gold

Bronze

Corten

Slice collection



SLICE PENDANT
202

STARLIGHT

designed by Serena Papait

Configurable geometries. Starlight is available in two sizes and numerous compositions: its changeable shape illuminates residential and professional settings with radiant reflections and plays of indirect light, for a suffused and soft effect.

Geometrie componibili.

Starlight è disponibile in due dimensioni e numerose composizioni: la sua forma mutevole illumina ambienti residenziali e professionali con riflessi luminosi e giochi di luce indiretti, per un effetto di soffusa morbidezza.

 WALL/CEILING LAMPS



STARLIGHT GIANT wall lamps | Bronze
AVANA composable sofa | M01/556 fabric, Eucalyptus table top and Umбра Grey legs
MIAMI side table | Fokos Terra porcelain stoneware top and Umбра Grey frame

Lighting & Acoustic Collection



DESIGN LIGHTING







Wall lamp

STARLIGHT

Wall lamp in powder coated aluminium.
Lampada a parete in alluminio verniciato.

Starlight
22W LED
2000 lm
110-240V
2700K
CRI90
ON-OFF

CE IP20  
UGR₁₉

Starlight Giant
47W LED
5400 lm
2700K
CRI90
DALI/Push dimm

CE IP20  
UGR₁₉

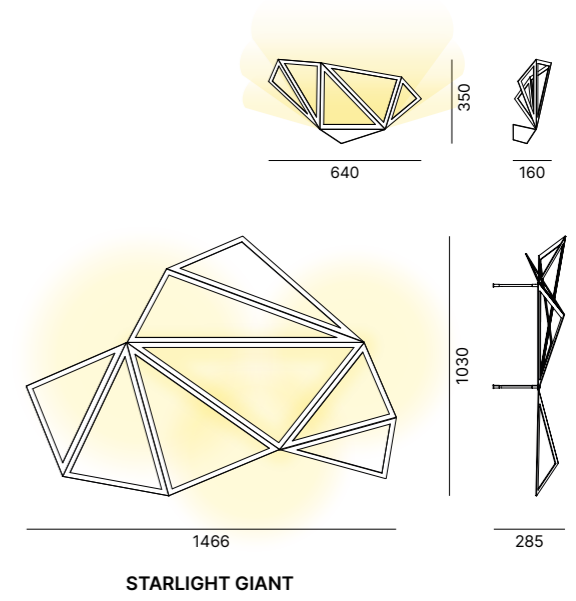

For the icon summary refer to pages 400 - 403 / Per la legenda icone vedere pp. 400 - 403

LAMP FINISH OPTIONS
FINITURE LAMPADA

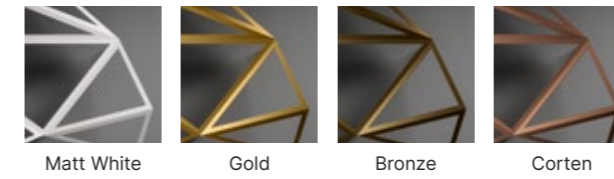

Matt White Gold Bronze Corten

Starlight collection



STARLIGHT PENDANT
208

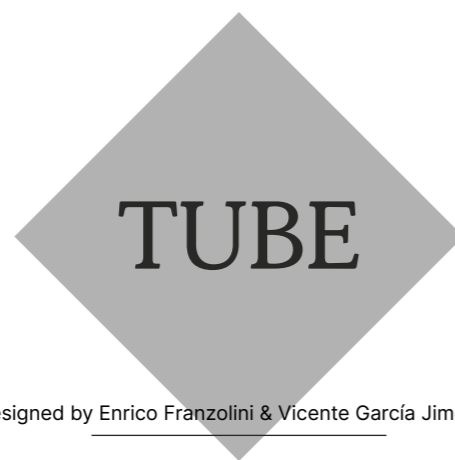

designed by Enrico Franzolini & Vicente García Jimenez

**Enlightened synthesis.
Available in the ceiling or
wall hung version, Tube is
the lighting solution suitable
for different project design
and aesthetic requirements:
two sizes, five finishings
and a multitude of
installation options.**

Sintesi illuminata.

Disponibile nella versione a soffitto o a parete, Tube è la soluzione di illuminazione adatta per diverse esigenze progettuali ed estetiche: due misure, cinque finiture e molteplici possibilità di installazione.



WALL/CEILING LAMPS





TUBE ceiling lamps | Black Goffratino lamp with Gold reflector
 CITY LOUNGE armchair | D05/413 fabric and Oak varnished solid ash wood legs
 MELBOURNE side table | Fokos Terra porcelain stoneware top and Oak varnished solid ash wood legs

Its light is punctual, a lamp that is simple in appearance but makes an impact in any space, whether residential or business.

La sua luce è puntuale, una lampada semplice all'apparenza ma d'impatto in qualsiasi spazio, sia residenziale che business.

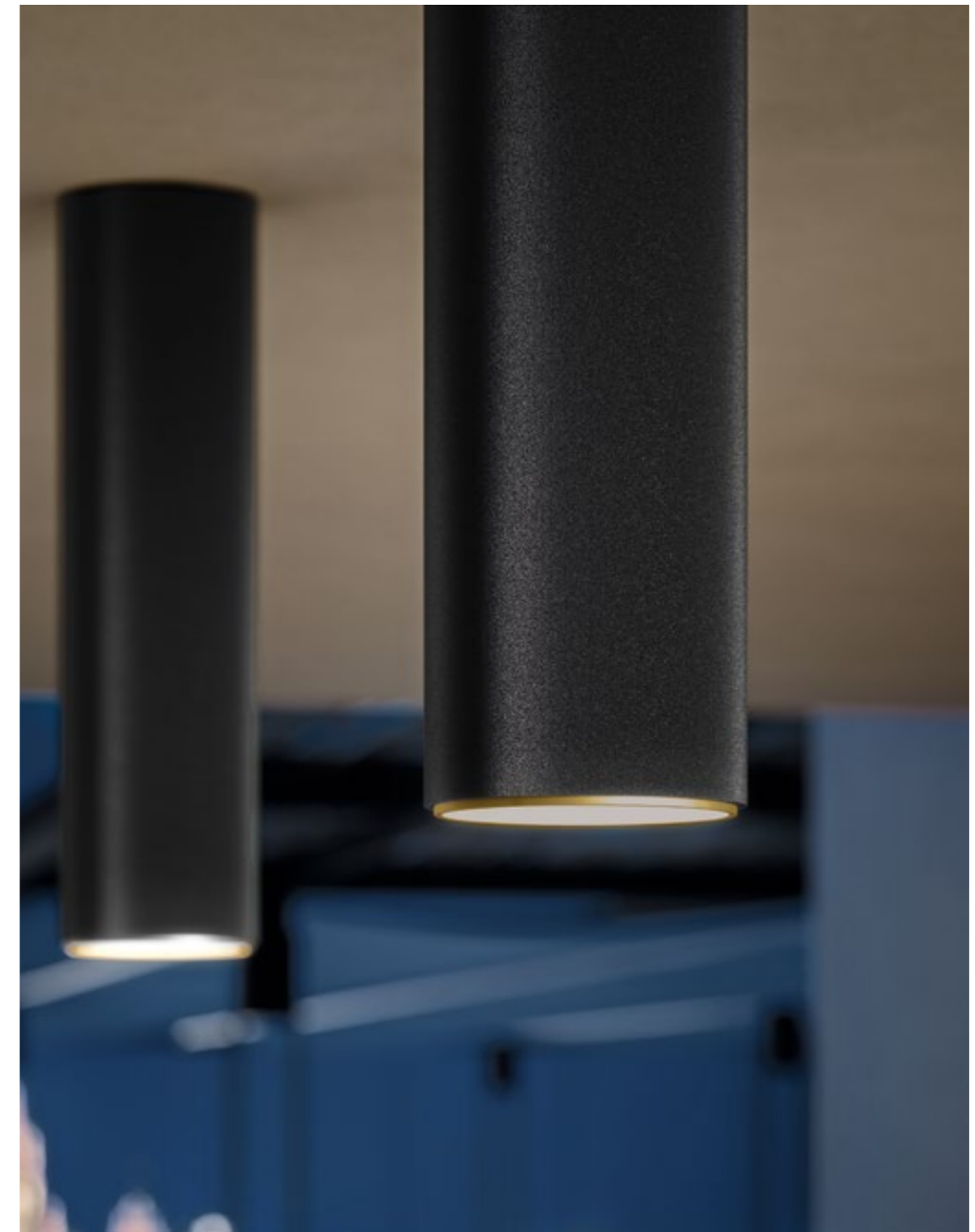



Ceiling lamp

TUBE

Ceiling lamp in powder coated aluminium.
Lampada a soffitto in alluminio verniciato.

6,3W LED
220-240V
2700K
CRI90
T/fase | DALI/Push dimm

CE IP20 LED 45-60° 880lm MacAdam Step 3 UGR₁₉

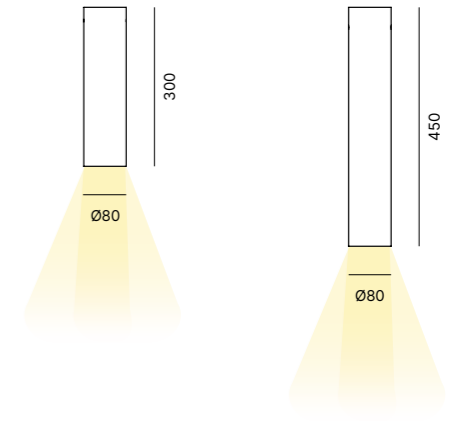

For the icon summary refer to pages 400 - 403 / Per la legenda icone vedere pp. 400 - 403

SHADE FINISH OPTIONS
FINITURE PARALUME

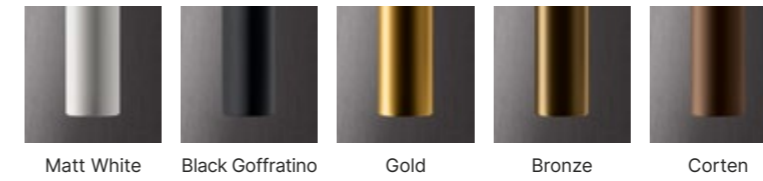

REFLECTOR FINISH OPTIONS
FINITURE RIFLETTORE



Tube collection

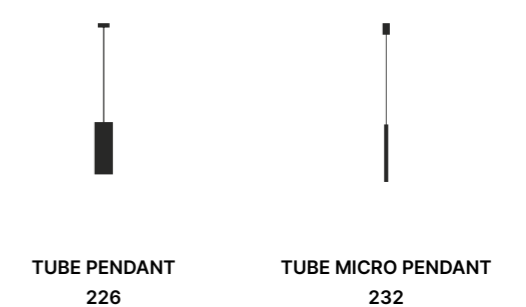



Wall lamp

TUBE

Wall lamp in powder coated aluminium.
Lampada a parete in alluminio verniciato.

12,6W LED
220-240V
2700K
CRI90
T/fase | DALI/Push dimm

CE IP20 LED 45-60° 1760lm MacAdam Step 3 UGR₁₉

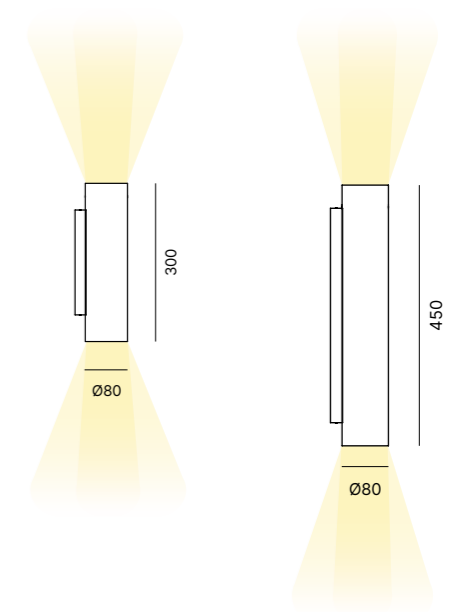

For the icon summary refer to pages 400 - 403 / Per la legenda icone vedere pp. 400 - 403

SHADE FINISH OPTIONS FINITURE PARALUME



REFLECTOR FINISH OPTIONS FINITURE RIFLETTORE



Tube collection

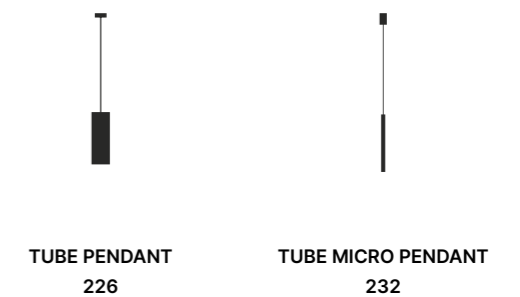

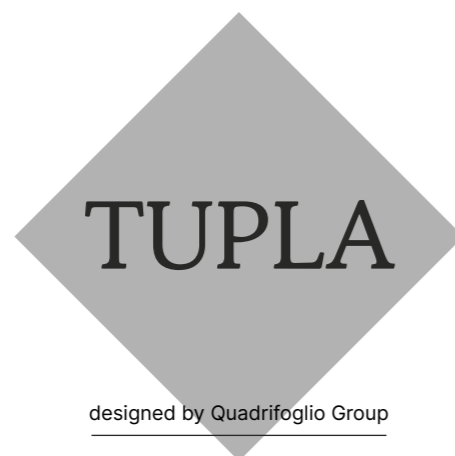

Pure light.
Tupla is the wall lamp for residential and hospitality settings: its simple and succinct shape, combined with the warm and adjustable light, creates a unique ambience every time.

Pura luce.
Tupla è la lampada a parete ideale per ambienti residenziali e di hospitality: la forma semplice e sintetica, unita alla luce calda e regolabile, crea un'atmosfera ogni volta unica.

WALL/CEILING LAMPS





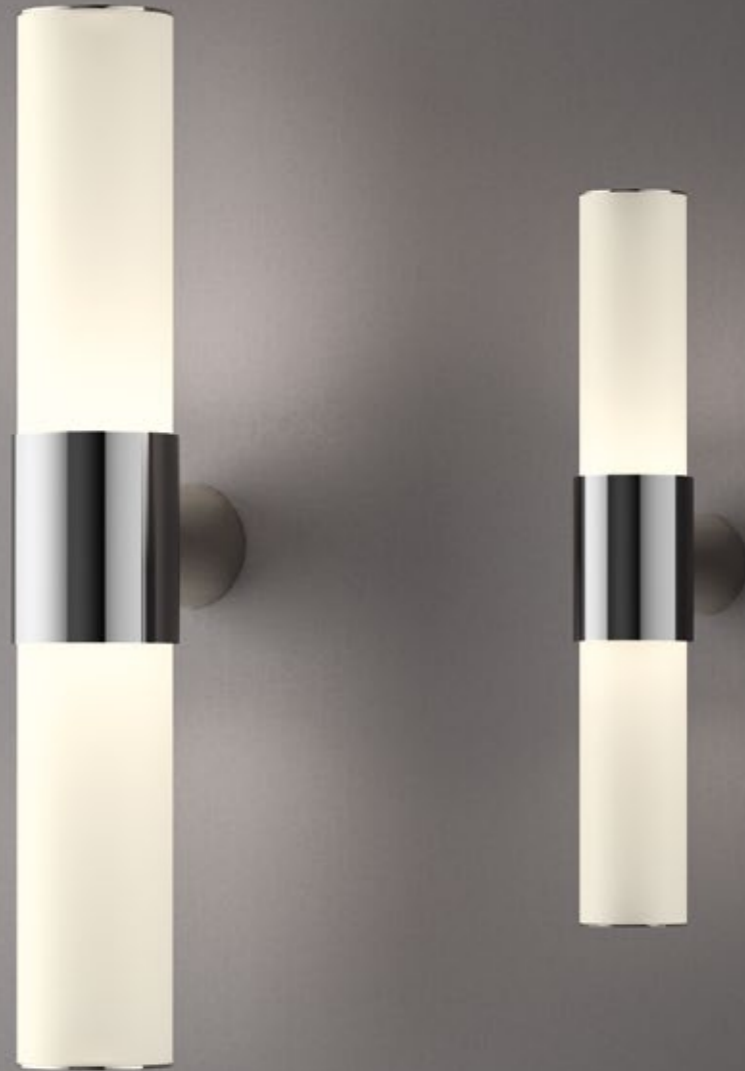

Wall lamp

TUPLA

Wall lamp with polished aluminium frame and matt methacrylate shade.

Lampada a parete con struttura in alluminio lucidato e paralume in metacrilato opalino.

Tupla 28

2X4,3W LED
800 lm
220-240V
2700K
CRI80
T/fase

Tupla 40

2X8,7W LED
1600 lm
220-240V
2700K
CRI80
T/fase

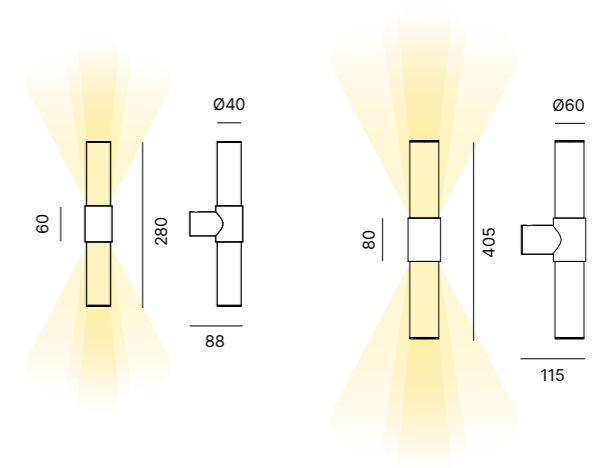

CE IP44   UGR₁₉

For the icon summary refer to pages 400 - 403 / Per la legenda icone vedere pp. 400 - 403

SHADE FINISH OPTIONS
FINITURE PARALUME

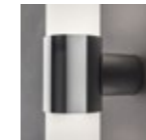

Polished
aluminium

TURN ME!

designed by Marta Laudani & Marco Romanelli

**Changeable personality.
Turn me! is the wall lamp
that innovates the concept
of lighting: thanks to its
rotating structure, light
can be directed any way,
according to needs.**

**Personalità mutevole.
Turn me! è la lampada a parete che innova
il concetto di illuminazione: grazie alla sua
struttura rotante, si può direzionare la luce a
piacimento a seconda delle necessità.**



WALL/CEILING LAMPS







Wall lamp

TURN ME!

Wall lamp in powder coated aluminium.
Lampada a parete in alluminio verniciato.

8W LED
220-240V
2700K
CRI80
T/fase

CE IP20   1300lm UGR₁₉

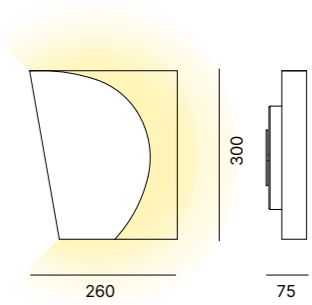

For the icon summary refer to pages 400 - 403 / Per la legenda icone vedere pp. 400 - 403

LAMP FINISH OPTIONS FINITURE LAMPADA

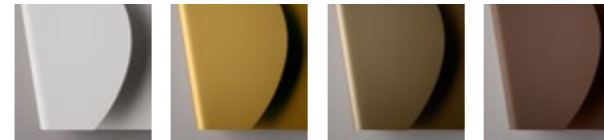

Matt White

Gold

Bronze

Corten

DETAILS DETTAGLI



Architectural Lighting

Minimalistic ambience. Comfort, authoritativeness, refinement, completeness: the sensations given off by any setting are all a matter of light. Architectural systems are modular and configurable, for complete freedom of design in living and professional settings.

Atmosfere minimal.
Accoglienza, autorevolezza, raffinatezza, completezza:
le sensazioni che restituisce uno spazio sono una
questione di luce. I sistemi architettonici sono modulabili
e componibili, per una completa libertà progettuale in
contesti living e professionali.



Family Index

Architectural Lighting



CARTESIO

AUROOM
BOND
GLOBE
MASTER
SPOTLIGHT
SLASH

CARTESIO

designed by Moreno De Giorgio

310

311





Cartesio characterises settings with discretion and conviction. It consists of a slender metal profile, dimmable led lights and a selection of different lamps for use as accessories, in order to create a more or less rich composition.

Cartesio caratterizza gli ambienti con discrezione e decisione: è formato da un profilo sottile in metallo, luci a led dimmerabili e diverse tipologie di lampade da utilizzare come accessori per rendere più o meno ricca o luminosa la composizione tra cui scegliere.





Designed to respond to a multitude of style requirements, Cartesio can be installed horizontally or vertically, wall or ceiling mounted, thanks to a series of combinable joints.

Progettato per rispondere a molteplici esigenze di stile, Cartesio si può installare sia in orizzontale, che in verticale, a parete e a soffitto, grazie a una serie di giunzioni combinabili.



Light points can be positioned along the track of Cartesio, such as spotlights, spheres, bars and other decorative elements, to personalise the lighting of settings big and small.

È possibile posizionare lungo il binario di Cartesio punti luce quali faretti, sfere, barre e altri elementi decorativi, per personalizzare l'atmosfera luminosa di ambienti di ampie e piccole dimensioni.





The Cartesio system marks the discovery of a new frontier of lighting: different options are available to direct light, including continuous, concentrated, diffuse or radiating forms, for tailored visual comfort.

Con il sistema Cartesio nasce una nuova frontiera dell'illuminazione: è possibile scegliere tra diverse opzioni per direzionare la luce, tra cui continua, concentrata, diffusa o radente, per un comfort visivo su misura.





Designed to provide elegant and functional lighting in a variety of settings, Cartesio guarantees the visual well-being of people, even in business spaces, encouraging concentration and productivity.

Progettato per illuminare diversi tipi di contesti in modo elegante e funzionale, Cartesio garantisce il benessere visivo delle persone anche negli spazi business, favorendo concentrazione e produttività.





Simple, linear, functional, with a strong aesthetic impact and adjustable in line with the intended context: Cartesio can be shaped according to design requirements, offering numerous possibilities for interpretation.

Semplice, lineare, funzionale, dal forte impatto estetico e modulabile in linea con il contesto di destinazione: Cartesio si lascia plasmare a seconda delle esigenze progettuali, offrendo numerose possibilità di installazione.

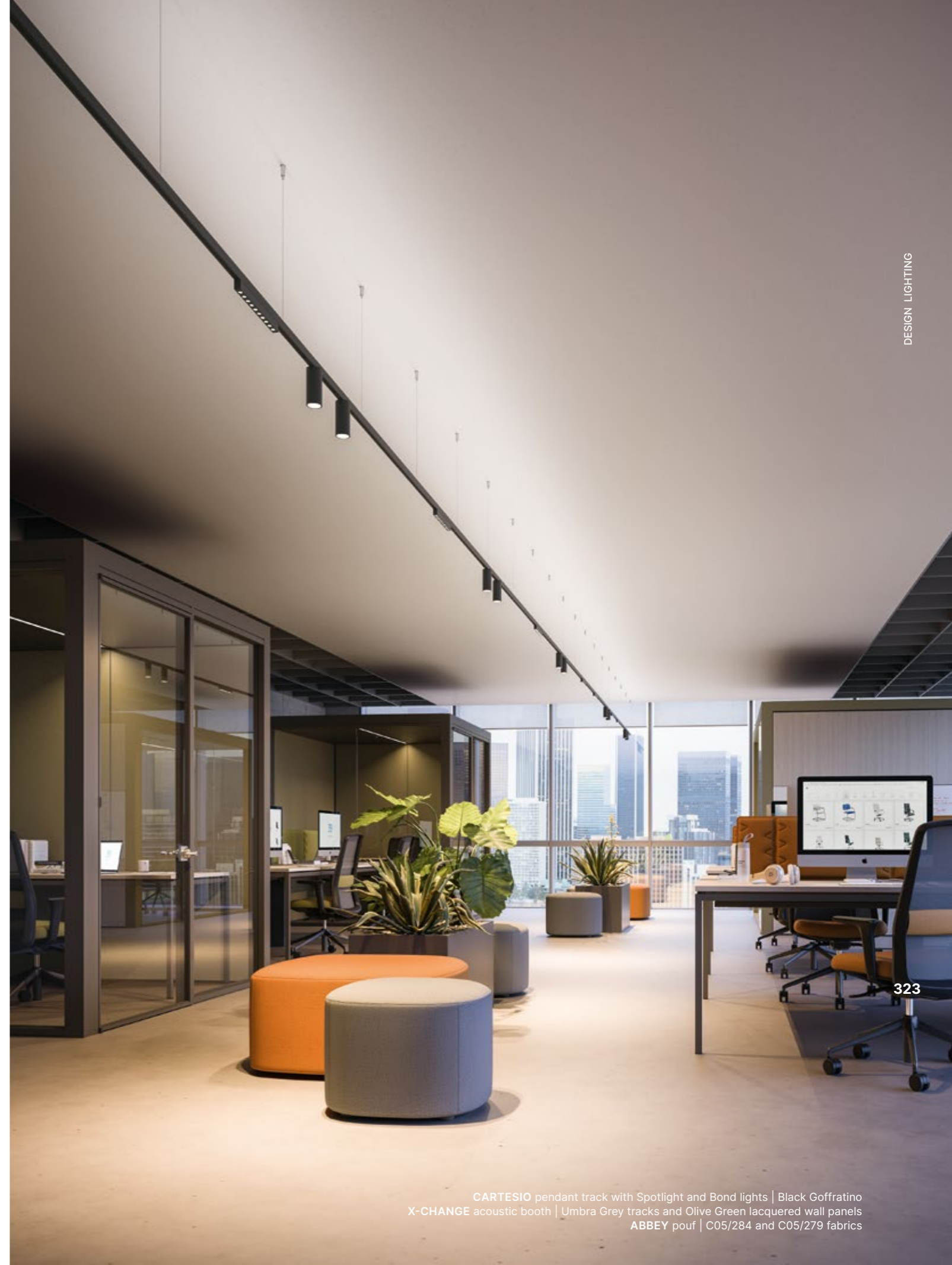



Wall / Ceiling track

CARTESIO

Micro track 48V
Micro binario 48V

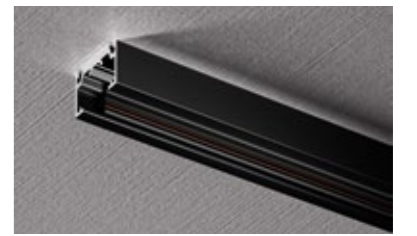
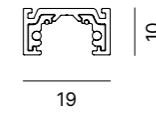

CE IP20

LENGHT / LUNGHEZZA
1000 - 2000 - 3000 mm

FINISH / FINITURA
Black Goffratino



For the icon summary refer to pages 400 - 403 / Per la legenda icone vedere pp. 400 - 403

Cartesio wall/ceiling tracklights



1. AUROOM

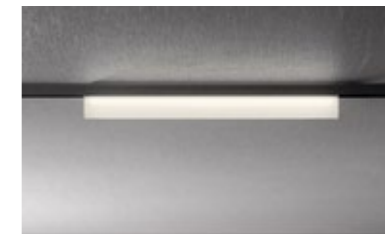

2. MASTER

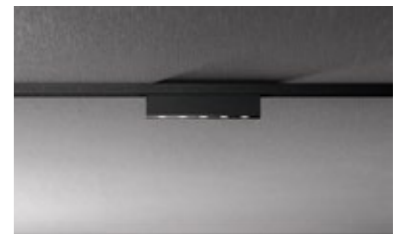

3. BOND



4. ADJUSTABLE SPOTLIGHT



5. SLASH



6. GLOBE



7. GLOBE PENDANT

Specifications at pages 328-329



Pendant track

CARTESIO

Micro track 48V
Micro binario 48V

CE IP20

LENGHT / LUNGHEZZA
1000 - 2000 - 3000 mm

FINISH / FINITURA
Black Goffratino

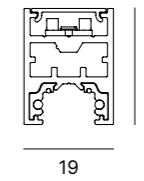

For the icon summary refer to pages 400 - 403 / Per la legenda icone vedere pp. 400 - 403

Cartesio pendant tracklights



1. GLOBE



2. AUROOM

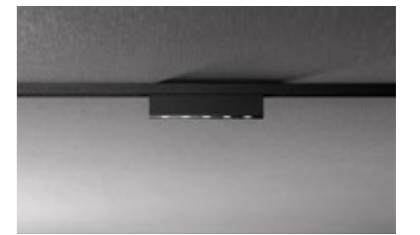

3. BOND

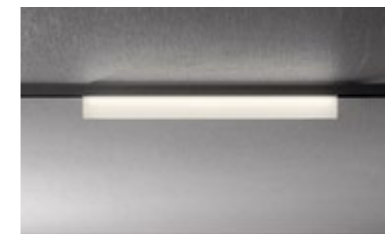

4. MASTER



5. FIXED SPOTLIGHT

Specifications at pages 328-329

Auroom

Straight down light W. 315/915mm
Lampada lineare diretta L. 315/915 mm

4,9W LED / 14,4W LED
CRI90
600 lm / 1800 lm
2700K / 3000K

CE IP20 LED 48V MacAdam Step 3 UGR₁₉



Master

Straight diffused light W. 315/915mm
Lampada lineare diffusa L. 315/915 mm

4,9W LED / 14,4W LED
CRI90
600 lm / 1800 lm
2700K / 3000K

CE IP20 LED 48V MacAdam Step 3 UGR₁₉



Slash

Triangular lamp W. 314mm
Lampada triangolare L. 314mm

4,9W LED
CRI90
600 lm
2700K / 3000K

CE IP20 LED 48V MacAdam Step 3 UGR₁₉



Bond

5 or 10-lights spotlight
Faretto 5 o 10 luci

5,7W LED / 11,1W LED
CRI90
525 lm / 1050 lm
2700K / 3000K

CE IP20 LED 48V 25-60° UGR₁₉



Spotlight

Adjustable spotlights Ø 30/43/53 mm
Faretti orientabili Ø 30/43/53 mm

3,2W / 10,6W / 13,9W - CRI90
177 lm / 720 lm / 1065 lm
2700K / 3000K

CE IP20 LED 48V 15-30° 15-30° MacAdam Step 3 UGR₁₉



Spotlight

Fixed spotlights Ø 30/43/53 mm
Faretti fissi Ø 30/43/53 mm

3,2W / 10,6W / 13,9W - CRI90
177 lm / 720 lm / 1065 lm
2700K / 3000K

CE IP20 LED 48V 15-30° MacAdam Step 3 UGR₁₉



Globe

Round lamp Ø 100/120 mm
Lampada sfera Ø 100/120 mm

3W LED
CRI90
420 lm
2700K / 3000K

CE IP20 LED 48V UGR₁₉



Globe

Round pendant lamp Ø 100/120 mm
Lampada sfera a sospensione Ø 100/120 mm

3W LED
CRI90
420 lm
2700K / 3000K

CE IP20 LED 48V UGR₁₉



Office Lighting

Light projects.
Responding to the operative and executive needs of an office means being able to skilfully combine the brightness, tonality and position of lights. Office lamps take centre stage as fundamental elements of visual comfort for people.

Progetti luminosi.

Rispondere alle esigenze operative e di rappresentanza di un ufficio significa combinare con sapienza intensità, tonalità e collocazione della luce. Le lampade da ufficio diventano protagoniste insostituibili del comfort visivo delle persone.

330



Family Index

Office Lighting

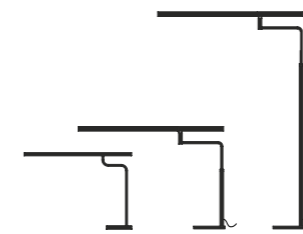

MINISTICK

MICROSTICK TABLE - 332
 MINISTICK TABLE - 338
 MINISTICK FLOOR - 344



MORE

MORE FLOOR - 350

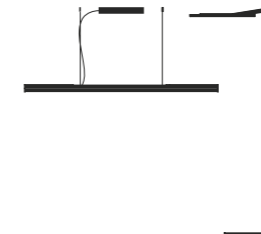

FLY

FLY FLOOR - 356
 FLY PENDANT - 362



EUSTRESS

EUSTRESS PENDANT - 368



LIGHTSOUND

TRIANGLE PENDANT LAMP
 EASY PENDANT LAMP
 CLOAK ACOUSTIC PANEL
 PETAL ACOUSTIC PANEL
 374 - 397

331

MICROSTICK

designed by Moreno De Giorgio

**Compact functionality.
Efficient and minimal,
Microstick is the desk
lamp par excellence, at
home or in the office. The
soft led light is adjustable
with a touch sensor for
superlative comfort.**

Funzionalità compatta.

Efficiente e minimale, Microstick è la lampada da scrivania per eccellenza, a casa o in ufficio. La luce soft a led è regolabile con un sensore touch per il massimo comfort.



TABLE LAMPS



334

335



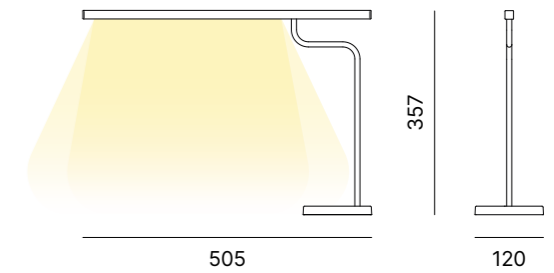

Table lamp

MICROSTICK

Table lamp in powder coated aluminium.
Lampada da tavolo in alluminio verniciato.

15,3W LED
220-240V
3000K
CRI80
Touch Dimm



CE IP20   800lm UGR₁₉

For the icon summary refer to pages 400 - 403 / Per la legenda icone vedere pp. 400 - 403

LAMP FINISH OPTIONS
FINITURE LAMPADA



Matt White

Black
Goffratino

DETAILS
DETTAGLI



Touch dimmer
function

Ministick collection

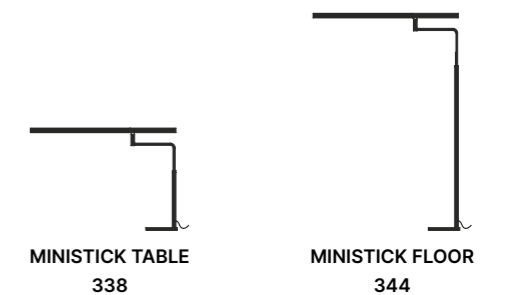

MINISTICK TABLE
338

MINISTICK FLOOR
344

MINISTICK

designed by Moreno De Giorgio

**Directions of light.
The essential design of
Ministick makes it perfect
for versatile use, thanks
to the microprismatic high
efficiency diffuser and the
position adjustment of this
table lamp.**

Direzioni di luce.

Il design essenziale di Ministick si presta a un utilizzo versatile, grazie al diffusore microprismatico ad alta efficienza e alla possibilità di regolare la posizione di questa lampada da tavolo



TABLE LAMPS



340

341

MINISTICK table lamps | Black Goffratino
X3 bench desk | Oak top, White and Oak frame
DIADE ROCK office chair | C05/284 fabric and White frame

Table lamp



MINISTICK

Table lamp in powder coated aluminium. Brushed anodized aluminium shade and high-efficiency microprismatic diffuser.

Lampada da tavolo in alluminio verniciato. Paralume in alluminio spazzolato anodizzato e diffusore microprismatico ad alta efficienza.

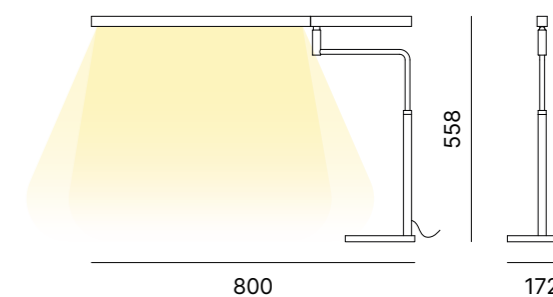
21,6W LED
110-240V
3000K
CRI90
Touch Dimm



CE IP20   24V 2395lm  MacAdam Step 3 UGR₁₉

For the icon summary refer to pages 400 - 403 / Per la legenda icone vedere pp. 400 - 403

LAMP FINISH OPTIONS
FINITURE LAMPADA

Matt White

Black
GoffratinoDETAILS
DETTAGLI

±170° rotation

±45° rotation

Touch dimmer
function

Ministick collection

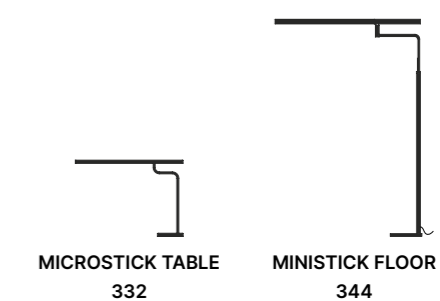
MICROSTICK TABLE
332MINISTICK FLOOR
344

MINISTICK

designed by Moreno De Giorgio

**Slender brightness.
Technology and beauty
meet in the Ministick floor
lamp: the simple and elegant
lines enclose a strong and
determined character and
are suitable for a world of
different configurations.**

Slanciata luminosità.

Tecnologia e bellezza si incontrano nella lampada da terra
Ministick: le linee semplici ed eleganti racchiudono un carattere
forte e deciso e si prestano a un mondo di configurazioni diverse.



FLOOR LAMPS



346

347

MINISTICK floor lamps | Black Goffratino
ACCORD high-back sofa | P01/095 leather and C05/280 fabric, Umbra Grey legs
T05 coffee table | Eucalyptus





Floor lamp

MINISTICK

Floor lamp in powder coated aluminium. Brushed anodized aluminium shade and high-efficiency microprismatic diffuser.

Lampada da terra in alluminio verniciato. Paralume in alluminio spazzolato anodizzato e diffusore microprismatico ad alta efficienza.

21,6W LED
110-240V
3000K
CRI90
Touch Dimm

CE IP20   24V 2395lm  MacAdam Step 3 UGR₁₉

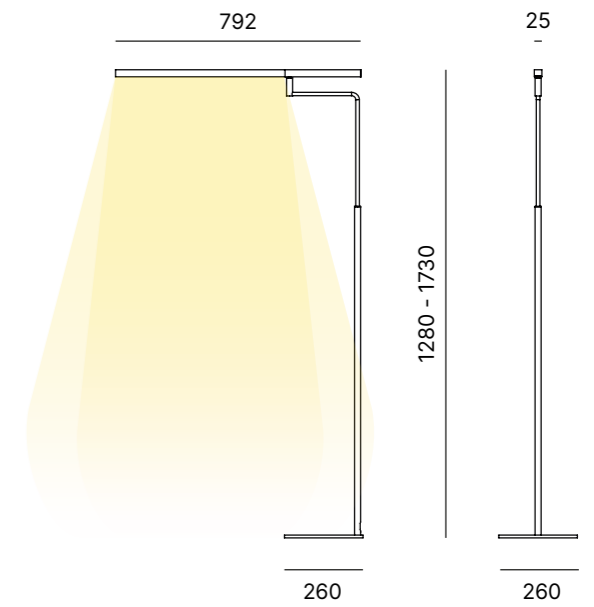

For the icon summary refer to pages 400 - 403 / Per la legenda icone vedere pp. 400 - 403

LAMP FINISH OPTIONS
FINITURE LAMPADA



Matt White

Black Goffratino

DETAILS
DETTAGLI

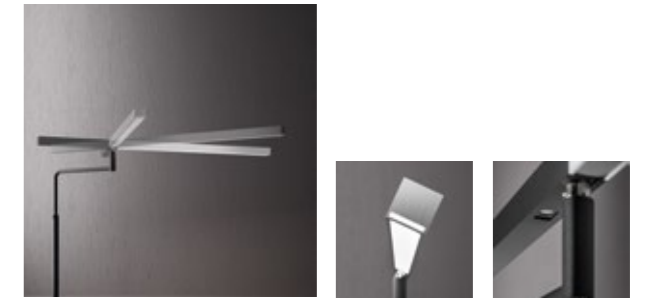

±170° rotation

±45° rotation

Touch dimmer function

Ministick collection

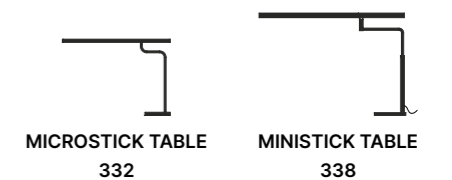

MICROSTICK TABLE
332

MINISTICK TABLE
338



designed by Moreno De Giorgio

**Measured forms.
Logic, power and linearity:
in More proportions,
technology and attention
to details bring to life
an essential and high-
performance lamp,
ideal for offices with a
contemporary look.**

Forme misurate.

Logica, potenza e linearità: in More le proporzioni, la tecnologia e la cura dei dettagli danno vita a una lampada essenziale e performante, ideale per gli uffici dal look contemporaneo.



FLOOR LAMPS



MORE floor lamp | Matt White
OXYGEN office chair | R06/230 mesh and C05/290 fabric, White frame
X3 bench desk | White and Oak legs, Oak top





354

Floor lamp

MORE

Floor lamp in powder coated aluminium.
Lampada da terra in alluminio verniciato.

| More 8 | More 12 | More 16 |
|------------|------------|------------|
| 82W LED | 133W LED | 149W LED |
| 8826 lm | 13760 lm | 18694 lm |
| 110-240V | 110-240V | 110-240V |
| 3000K | 3000K | 3000K |
| CRI90 | CRI90 | CRI90 |
| Touch Dimm | Touch Dimm | Touch Dimm |

CE IP20    MacAdam Step 3 UGR₁₉

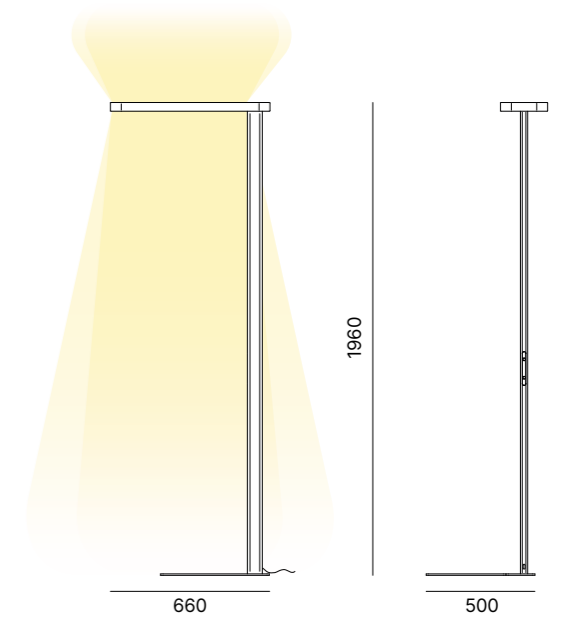

DESIGN LIGHTING

For the icon summary refer to pages 400 - 403 / Per la legenda icone vedere pp. 400 - 403

LAMP FINISH OPTIONS
FINITURE LAMPADA

Matt White

Black
goffratinoDETAILS
DETTAGLITouch dimmer
function

355



**Sophisticated lightness.
Fly stands out for its
aerodynamic silhouette and
fluid design: a floor lamp
that ensures a characteristic
and enveloping light, ideal
for workspaces with a
refined soul.**

**Sofisticata leggerezza.
Fly si distingue per la silhouette aerodinamica e il design fluido:
una lampada da terra che assicura una luce caratteristica e
avvolgente, ideale per gli spazi di lavoro dall'animo ricercato.**

356



FLOOR LAMPS



357

FLY floor lamp | Matt White
X3 desk | White top and legs
DIADE ROCK office chair | C05/290 fabric and White frame





360

Floor lamp

FLY

Floor lamp in powder coated aluminium.
Lampada da terra in alluminio verniciato.

| Fly 8 | Fly 12 | Fly 16 |
|------------|------------|------------|
| 88W LED | 114W LED | 154W LED |
| 8978 lm | 12653 lm | 18778 lm |
| 110-240V | 110-240V | 110-240V |
| 3000K | 3000K | 3000K |
| CRI90 | CRI90 | CRI90 |
| Touch Dimm | Touch Dimm | Touch Dimm |

CE IP20   24V  MacAdam Step 3 UGR₁₉

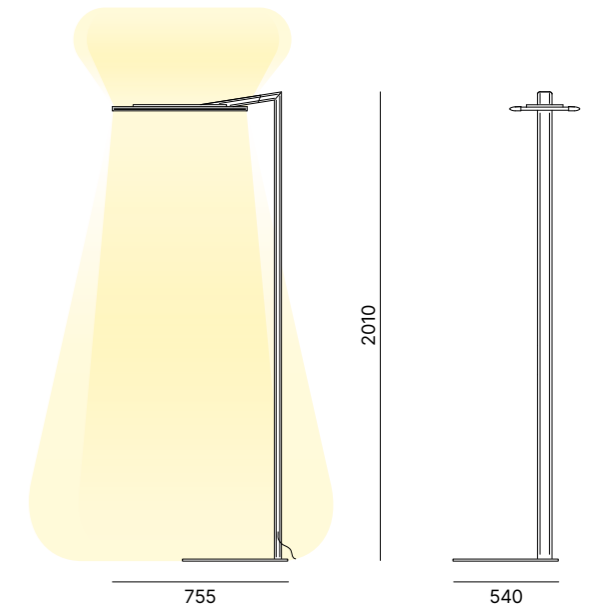

DESIGN LIGHTING

For the icon summary refer to pages 400 - 403 / Per la legenda icone vedere pp. 400 - 403

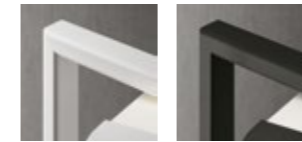
LAMP FINISH OPTIONS
FINITURE LAMPADA

Matt White

Black
goffratinoDETAILS
DETTAGLITouch dimmer
function

Fly collection

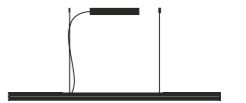
FLY PENDANT
362

361



**Aerial delicacy.
Pure lines with an iconic
style: the Fly suspension
lamp illuminates design
environments with a touch
of shining beauty, thanks to
the white and thin structure
that characterises it.**

Delicatezza aerea.
Linee pure dallo stile iconico: la lampada a sospensione
Fly illumina gli ambienti di design con un tocco di
splendente bellezza, grazie alla struttura bianca e
sottile che la caratterizza.



PENDANT LAMPS







Pendant lamp

FLY

Pendant lamp in powder coated aluminium.
Lampada a sospensione in alluminio verniciato.

| Fly 120 | Fly 160 |
|---------|---------|
| 23W LED | 27W LED |
| 2438 lm | 2862 lm |
| 3000K | 3000K |
| CRI90 | CRI90 |
| ON-OFF | ON-OFF |

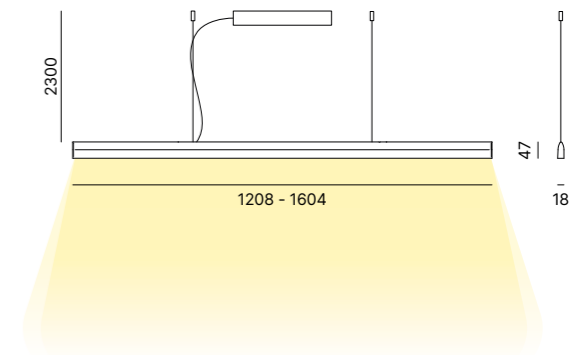

CE IP20 LED 24V MacAdam Step 3 UGR₁₉

For the icon summary refer to pages 400 - 403 / Per la legenda icone vedere pp. 400 - 403

LAMP FINISH OPTIONS
FINITURE LAMPADA

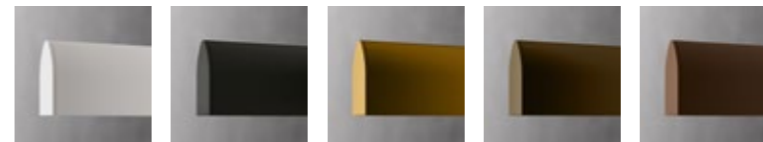

Matt White Black Goffratino Gold Bronze Corten

Fly collection



FLY FLOOR
356

EUSTRESS

designed by Moreno De Giorgio

Bright paths.
Eustress has a minimal and unconventional spirit, defined by its trapezoidal shape: with the latest generation LED and microprismatic diffuser, this lamp creates a contemporary form of lighting.

Vie luminose.

Eustress ha uno spirito minimale e anticonformista, definito dalla sua forma trapezoidale: con il led di ultima generazione e il diffusore microprismatico, questa lampada crea una forma contemporanea di illuminazione.



PENDANT LAMPS



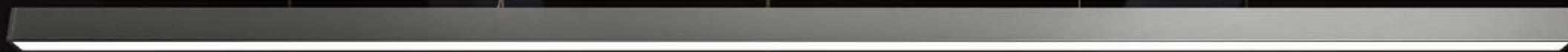

370

371



EUSTRESS pendant lamp | Anodized aluminium
X3 meeting table | Oak top and White legs

Pendant lamp

Pendant lamp in powder coated aluminium.
Lampada a sospensione in alluminio verniciato.

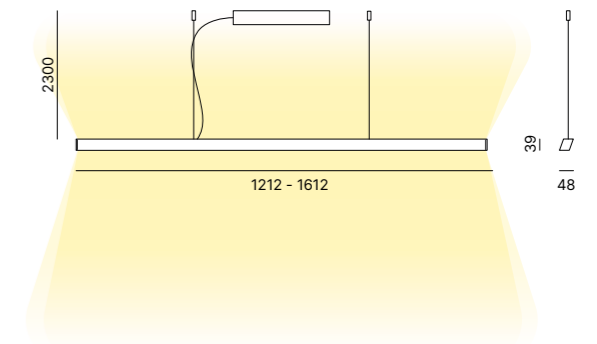
| Eustress 120 | Eustress 160 |
|---------------------|---------------------|
| 37W LED | 45W LED |
| 3922 lm | 4770 lm |
| 3000K | 3000K |
| CRI90 | CRI90 |
| ON-OFF All in one | ON-OFF All in one |



CE IP20   24V  MacAdam Step 3 UGR₁₉

For the icon summary refer to pages 400 - 403 / Per la legenda icone vedere pp. 400 - 403

LAMP FINISH OPTIONS
FINITURE LAMPADA

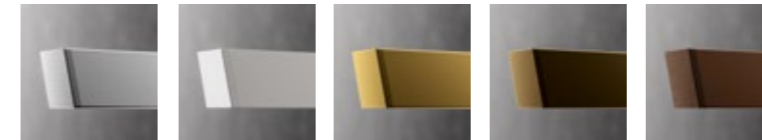

Anodized aluminium

Matt White

Gold

Bronze

Corten

LIGHTSOUND

designed by Moreno De Giorgio

**Sensory design.
Visual and auditory
well-being: this is what
is perceived in a public
space furnished with
Lightsound, the modular
system of lights and
sound-absorbing panels.**

Design sensoriale.
Benessere visivo e uditivo: è ciò che si percepisce in
uno spazio pubblico arredato con Lightsound, il sistema
componibile di luci e pannelli fonoassorbenti.



ACOUSTIC ELEMENTS



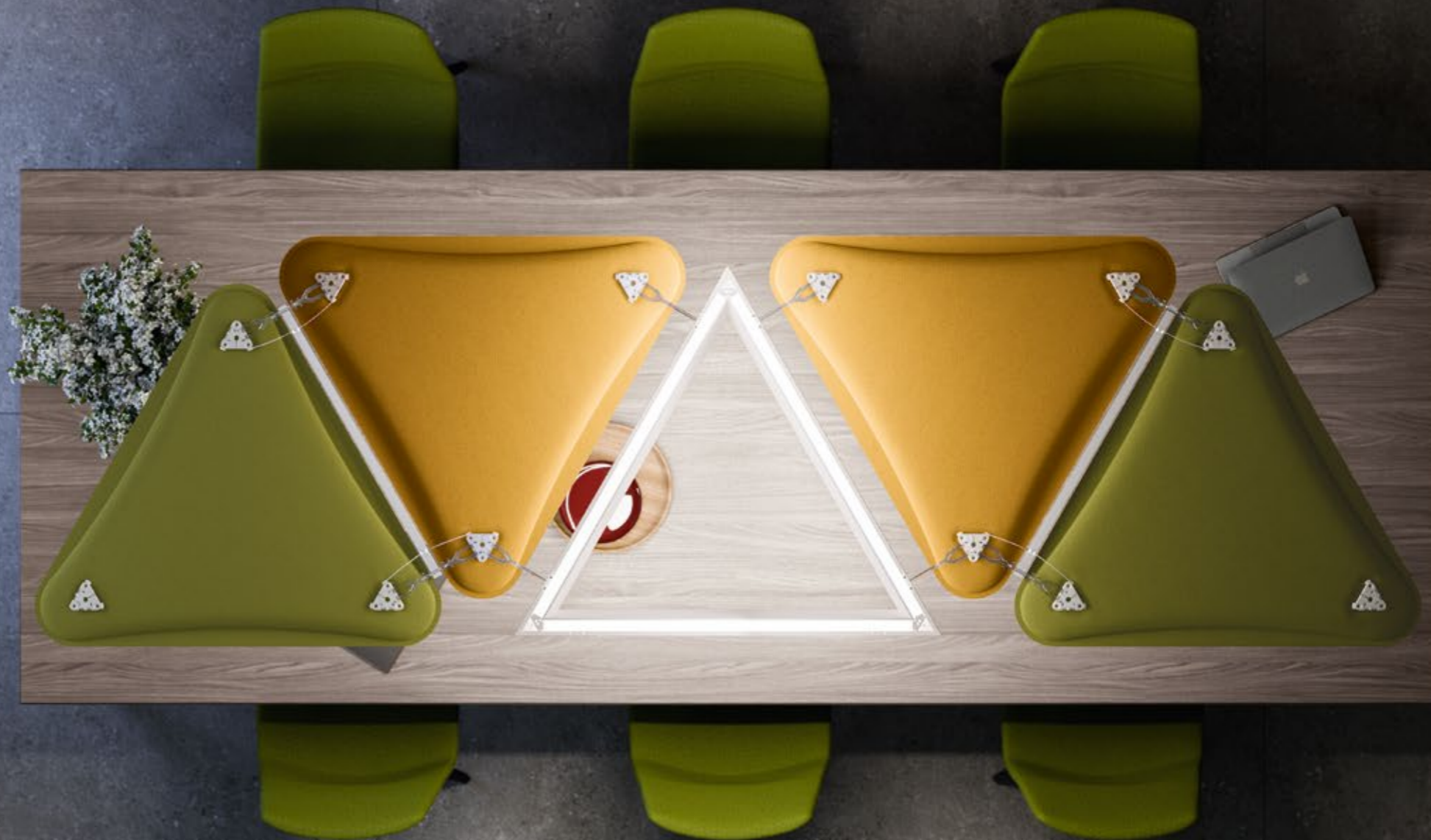

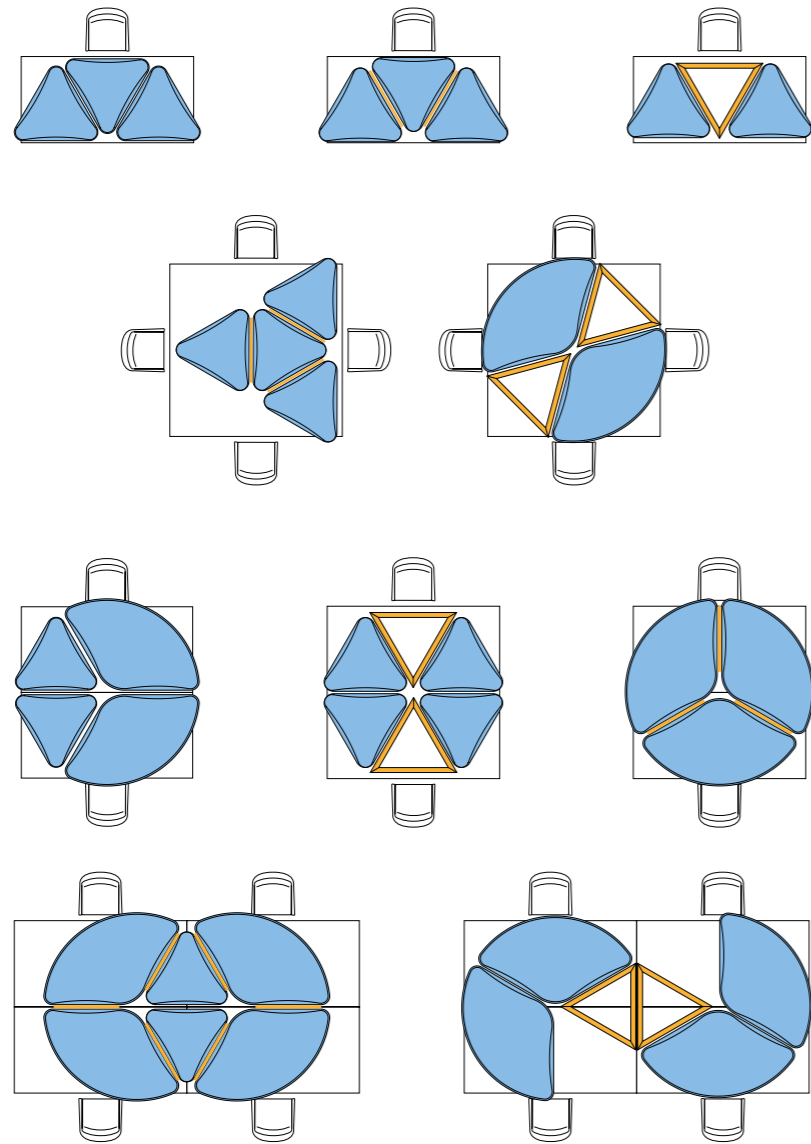

LIGHTSOUND system | B01/012 and B01/023 Cloak and Petal panels, Matt White Triangle lamps
COVE design chair | White shell and Oak varnished solid ash wood legs
X3 meeting table | White top, White and Oak frame





382

Panels are triangular or with a 120° angle and can be matched with Easy and Triangle leds. Lightsound can be installed suspended or wall hung to create shared spaces that are a pleasure to inhabit.

I pannelli sono triangolari oppure con un angolo di 120° e si possono abbinare ai led Easy e Triangle. Lightsound si installa sia a sospensione sia a parete per creare spazi condivisi piacevoli da vivere.



383





386

Lightsound can be assembled according to taste and customised with different cover colour options. The panels can also be arranged in the ceiling mounted cascade version, which is ideal for open spaces, hotel lobbies and restaurants.

Lightsound è componibile a piacimento e personalizzabile nei colori dei rivestimenti. I pannelli si possono disporre anche nella versione a cascata dal soffitto, ideali per open space, sale di hotel e ristoranti.

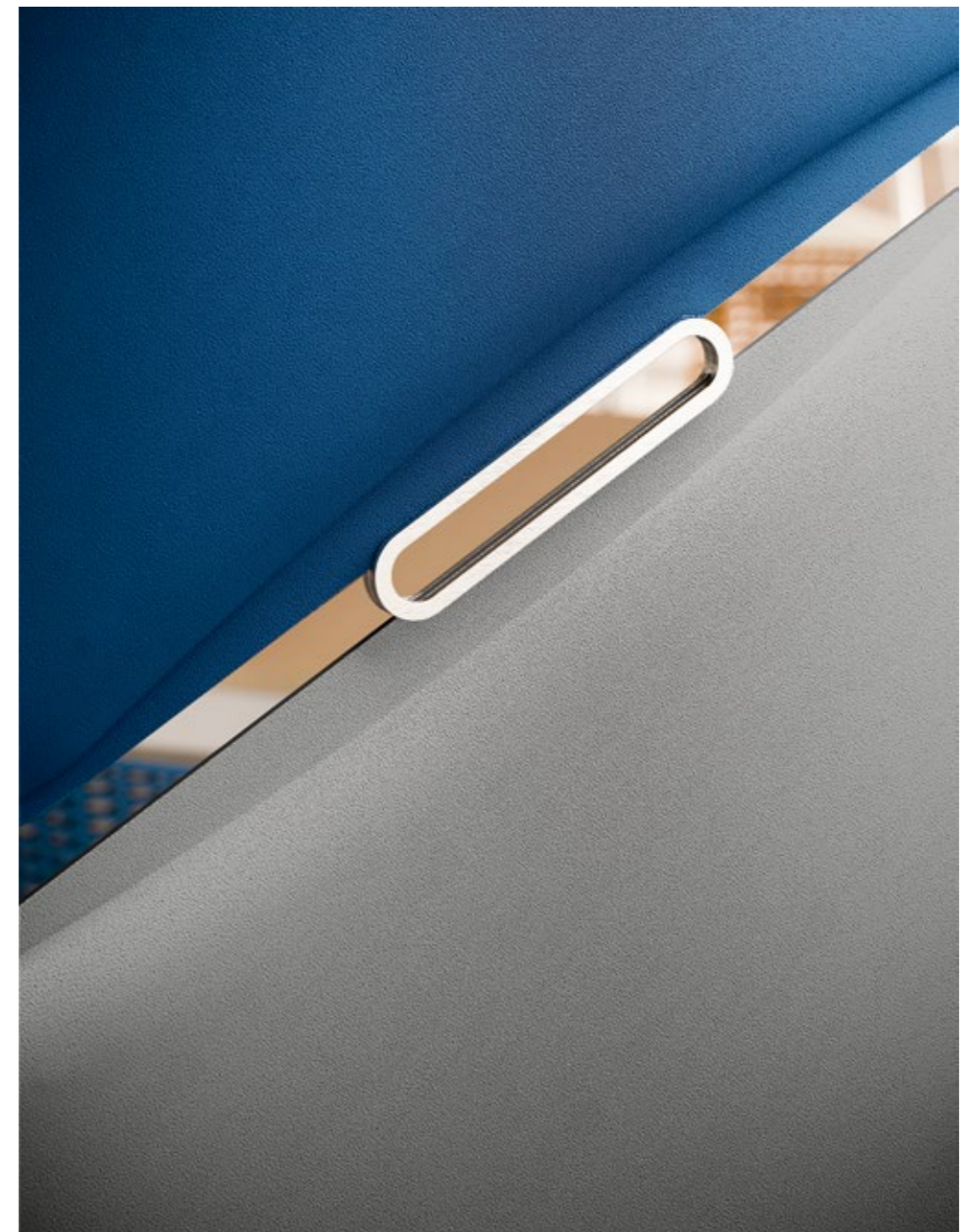

387

PETAL floor stand with acoustic panels | B01/020, B01/009 and B01/024 fabrics, Matt White frame
CODE high stool | Oak varnished solid ash wood shell with C05/280 upholstered seat, Chrome frame
ADO sofa and armchair | M01/590 fabric, Umbra Grey frame and Oak varnished solid ash wood arms





Pendant lamp

TRIANGLE

Pendant lamp in anodized or powder coated aluminium.
Lampada a sospensione in alluminio anodizzato o verniciato.



Down light

31W LED
3286 lm
3000K
CRI90
ON-OFF | All in one

Up/Down light

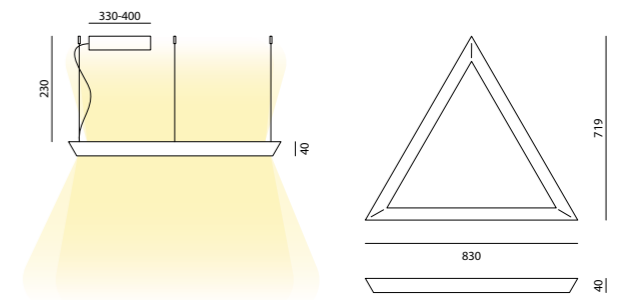
49W LED
5194 lm
3000K
CRI90
ON-OFF | All in one



CE IP20   24V  MacAdam Step 3 UGR₁₉

For the icon summary refer to pages 400 - 403 / Per la legenda icone vedere pp. 400 - 403

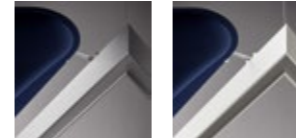
LAMP FINISH OPTIONS
FINITURE LAMPADAAnodized
aluminium

Matt White

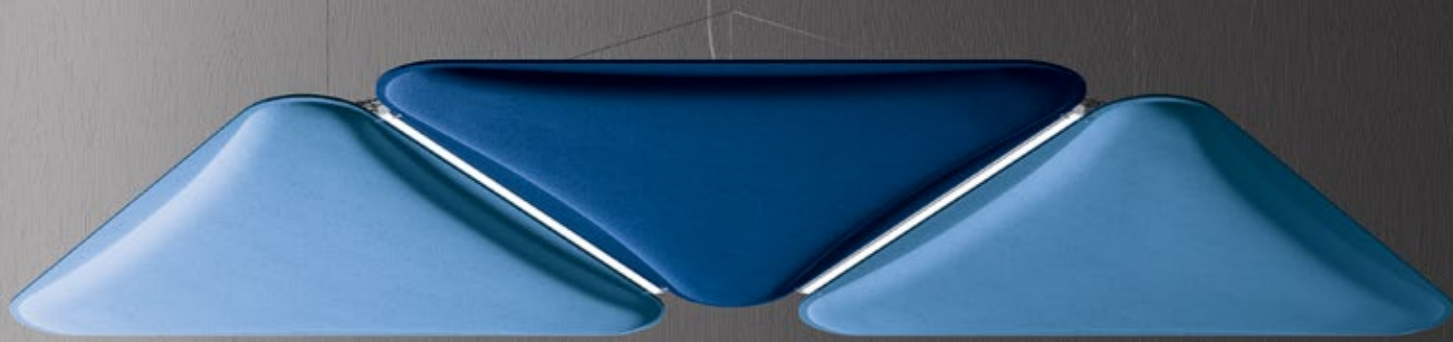



Pendant lamp

EASY

Pendant lamp in anodized aluminium.
Lampada a sospensione in alluminio anodizzato.

11,6W LED
3000K
CRI80

CE IP20   24V 1230lm  MacAdam Step 3 UGR₁₉

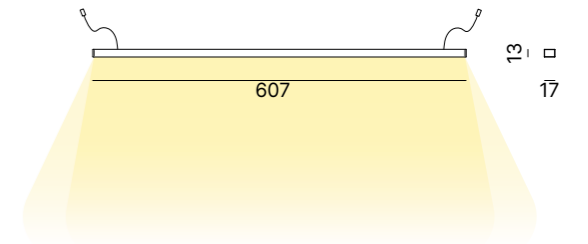

For the icon summary refer to pages 400 - 403 / Per la legenda icone vedere pp. 400 - 403

LAMP FINISH OPTIONS FINITURE LAMPADA



Anodized aluminium



Acoustic panel

CLOAK

Pendant or wall-mounted sound-absorbing triangular panel, fabric upholstered.
 Pannello fonoassorbente triangolare, a parete o sospensione, rivestito in tessuto.

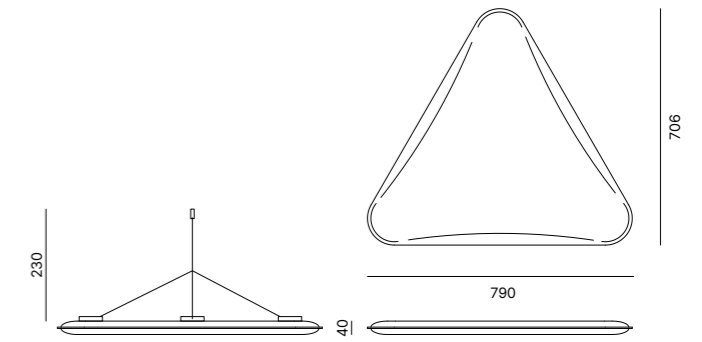

PANELS FINISH OPTIONS
 FINITURE PANNELLI

| | | | | | | | |
|----------|----------|----------|----------|----------|----------|----------|----------|
| B01/009 | B01/013 | B01/023 | B01/012 | B01/010 | B01/011 | B01/019 | B01/222 |
| On stock | On stock | On stock | On stock | On stock | On stock | On stock | On stock |

DETAILS
 DETTAGLI

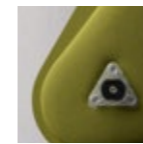

Linking



Acoustic panel

PETAL

Pendant or wall-mounted sound-absorbing 120° panel, fabric upholstered.
Pannello fonoassorbente 120°, a parete o sospensione, rivestito in tessuto.

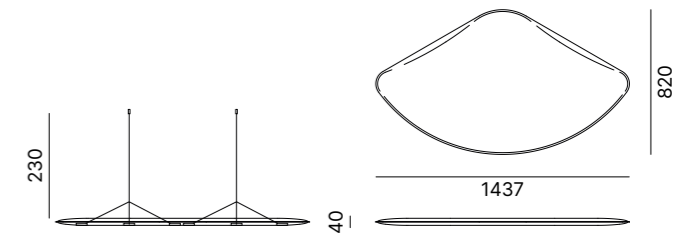

PANELS FINISH OPTIONS FINITURE PANNELLI



DETAILS DETTAGLI

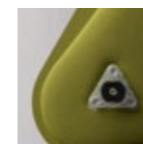

Linking

Acoustic panel

PENDANT CLOAK

Pendant sound-absorbing triangular panel, fabric upholstered.

Pannelli triangolari fonoassorbenti rivestiti in tessuto, a sospensione verticale.

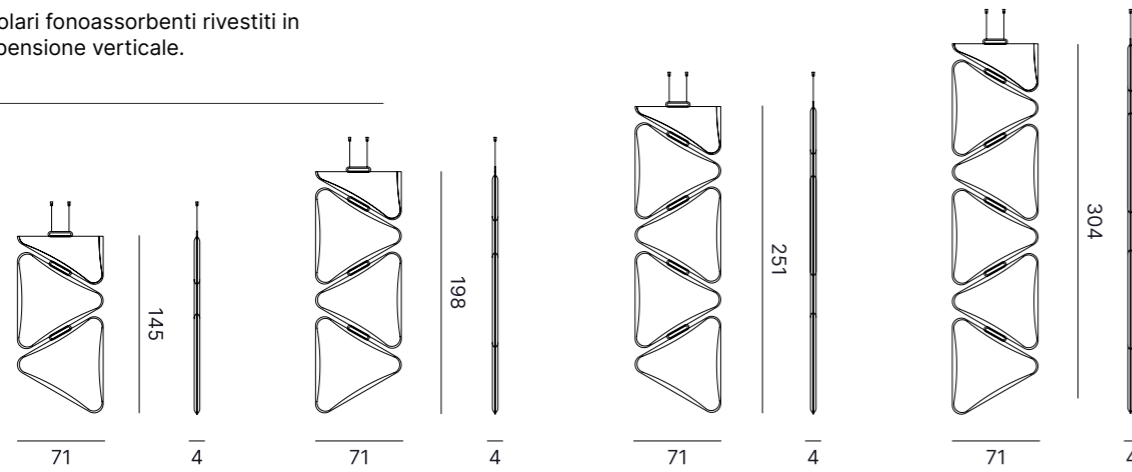

PANELS FINISH OPTIONS FINITURE PANNELLI

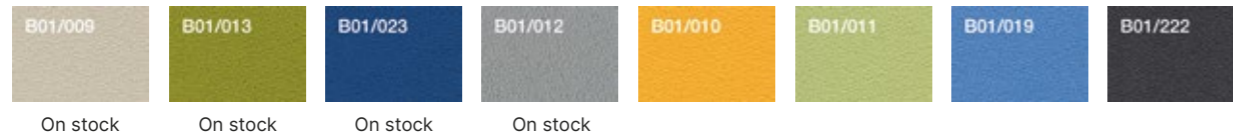

STRUCTURE FINISH OPTIONS FINITURE STRUTTURA



Acoustic panel

PETAL FLOOR STAND

Powder coated metal frame. 3 fabric upholstered sound-absorbing panels.

Piantana in metallo verniciato. 3 pannelli fonoassorbenti 120° rivestiti in tessuto.

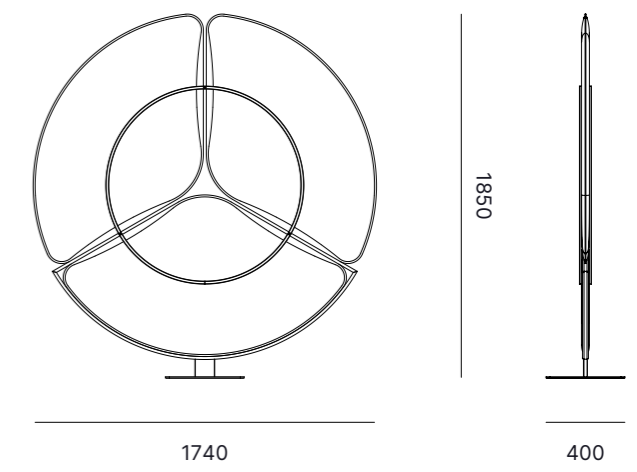

PANELS FINISH OPTIONS FINITURE PANNELLI



FRAME FINISH OPTIONS FINITURE PIANTANA



SYMBOL LEGEND

LEGENDA SIMBOLI

MARKING
MARCATURA

CE A mark that manufacturers of certain kinds of products must affix to ensure that the goods offered for sale meet the essential safety requirements of the regulations, trading and use of the product in the European Community.

La marcatura CE è un logo che attesta la conformità di un prodotto alla normativa dell'Unione Europea e certifica la rispondenza ai requisiti di sicurezza previsti dalla normativa, quelli di commercializzazione e utilizzo di un prodotto nello spazio economico comunitario.

PROTECTION DEGREE
GRADO DI PROTEZIONE

IP20 Il codice IP indica il livello di protezione degli involucri contro l'accesso a parti pericolose interne dell'involucro e contro la penetrazione di corpi solidi estranei e di liquidi.

The IP20 rating indicates the enclosures' level of protection against access to dangerous parts inside the enclosure and against penetration by solid foreign objects and liquids.

INSULATION CLASSES
GRADO DI PROTEZIONE

CLASS I - Earthing
Class I insulation is used to identify devices that require an additional safety measure consisting of the connection of the accessible conductive parts to a protective conductor (protective earthing). The latter is connected to the fixed electrical system and prevents the accessible conductive parts to become live in the event of a failure of the main insulation.

CLASSE I - Messa a terra
La classe I di isolamento viene usata per identificare gli apparecchi che necessitano di una misura di sicurezza supplementare costituita dalla connessione delle parti conduttrici accessibili ad un conduttore di protezione (messa a terra di protezione). Quest'ultimo, facendo capo all'impianto elettrico fisso, permette che le parti conduttrici accessibili non vadano in tensione in caso di guasto dell'isolamento principale.

CLASS II - Double insulation
Class II insulation, also called "double-insulated", are designed so that they do not require an earth connection. In Class II products, a single fault cannot cause the user to come into contact with dangerous voltages

CLASSE II - Doppio isolamento
La classe II di isolamento identifica gli apparecchi detti "a doppio isolamento": questi, infatti, sono progettati per non necessitare la connessione della messa a terra. Nei prodotti di classe II un singolo guasto non può causare il contatto con tensioni pericolose da parte dell'utilizzatore.

CLASS III - Insulation
Class III insulation indicates equipment that is powered by battery or by a SELV transformer. The voltage produced, which is less than 25V AC or 60V DC, is low to the point that it is not normally dangerous in the event of contact with the human body. Therefore, Class III equipment must not be provided with protective earthing.

CLASSE III - Isolamento
La classe III di isolamento identifica gli apparecchi che vengono alimentati a batteria o da un trasformatore SELV. La tensione prodotta, inferiore ai 25V AC o 60V DC, è bassa al punto da non essere normalmente pericolosa in caso di contatto con il corpo umano. Pertanto, gli apparecchi di classe III non devono essere provvisti di messa a terra di protezione.

LUMINOUS FLUX
FLUSSO LUMINOSO

720lm
lm (lumen)

Luminous flux is the amount of light emitted by a luminaire and is measured in lumens. Knowing the luminous flux of luminaires helps, from the earliest stages of design, to predimension the lighting so that we can match the atmosphere we want to convey with the finished space.

Il flusso luminoso è la quantità di luce emessa da un apparecchio di illuminazione e si misura in lumen. Conoscere il flusso luminoso degli apparecchi aiuta, fin dalle prime fasi della progettazione, a predimensionare l'illuminazione per poter far coincidere l'atmosfera che vogliamo trasmettere con lo spazio finito. Il flusso luminoso è la quantità di luce emessa da una certa sorgente o apparecchio di illuminazione.

MACADAM STEP 3

 The MacAdam index is a key parameter for evaluating the quality of LEDs in order to assess their color constancy and luminous accuracy. To the human eye, color variations within the 3rd step of the MacAdam ellipse are imperceptible.

L'indice MacAdam è un parametro fondamentale per valutare la qualità dei led al fine di valutarne la costanza cromatica e la precisione luminosa. Per l'occhio umano, le variazioni di colore entro il 3° step dell'ellisse MacAdam sono impercettibili.

COLOR RENDERING INDEX
INDICE DI RESA CROMATICA

CRI90 The Color Rendering Index – CRI is an index ranging from 0 to 100, and it identifies the ability of a light source to faithfully render the colours of an illuminated object.

L'indice di Resa Cromatica (Color Rendering Index – CRI) è un parametro che può variare da 0 a 100, e identifica la capacità di una sorgente luminosa di restituire fedelmente i colori di un oggetto illuminato.

INSTALLATION
APPLICAZIONE

 **Ceiling installation. The direction of the beam is vertical**
Applicazione a soffitto: la direzione del fascio luminoso è verticale.

 **Wall application. The direction of the beam is lateral**
Applicazione a parete: la direzione del fascio luminoso è laterale.

BEAM ANGLE
ANGOLO FASCIO LUMINOSO

15° - 30° The angle of the light beam refers to the width of the light beam produced by the light body.

L'angolo di fascio luminoso rappresenta l'ampiezza del fascio di luce creato dal corpo luminoso.

COLOUR TEMPERATURE
TEMPERATURA COLORE

2700K Colour temperature refers to the tone of white light emitted by a light source. This value is expressed in degrees Kelvin (K) with a scale from 1000 to 12000. The higher the Kelvin number, the whiter or bluer the light will appear.

From 2000K to 3000K identify the temperatures attributable to "warm colors" by their characteristic yellow-orange hue.
From 3300K to 5300K identify temperatures attributable to "cool white colors"
From 5300K to 5300K identify temperatures that can be traced back to the white/blueish colors of daylight.

La temperatura di colore si riferisce alla tonalità della luce bianca emessa da una sorgente luminosa. Questo valore viene espresso in gradi Kelvin (K) con una scala da 1000 a 12000. Più alto il numero di Kelvin, più bianca o bluastra apparirà la luce.
Da 2000K a 3000K = identificano le temperature riconducibili ai "colori caldi" per il loro caratteristico colorito giallo-arancione.
Da 3300K a 5300K = identificano le temperature riconducibili ai "colori bianchi freddi"
Da 5300K = identificano le temperature che si riconducono ai colori della luce bianco/bluastra del giorno.

COMMANDS COMANDI

LIGHT SOURCE FONTE LUMINOSA

| | |
|---------------------------------------|--|
| ON/OFF | Control indicating the ON/OFF switch. Comando che identifica l'interruttore di ACCENSIONE/SPEGNIMENTO. |
| DALI | LIGHT INTENSITY CONTROL CONTROLLO INTENSITÀ LUMINOSA DALI: Digital Addressable Lighting Interface. Communication protocol for managing the switching on/off/dimming of light sources in a timely and reprogrammable manner. DALI: Digital Addressable Lighting Interface. Protocollo di comunicazione che consente di gestire accensione/spegnimento/ dimmerazione delle fonti luminose in modo puntuale e riprogrammabile. |
| Touch dimm | Command that allows you to control the brightness variation with the touch of the sensor (capacitive). Comando che permette di controllare la variazione della luminosità con il tocco del sensore (capacitivo). |
| Push dimm | Command that allows you to control the brightness variation by holding down the button. Comando che permette di controllare la variazione della luminosità tenendo premuto il pulsante. |
| Potenziometer Potenziometro | Command that allows you to control the brightness variation by turning the dimmer clockwise or anticlockwise. (The resistance varies). Comando che permette di controllare la variazione della luminosità ruotando il dimmer in senso orario o antiorario. (Varia la resistenza). |
| 0-10V/1-10V | Command that allows you to control the brightness variation by turning the dimmer clockwise or anticlockwise. (The voltage varies). Comando che permette di controllare la variazione della luminosità ruotando il dimmer in senso orario o antiorario. (Varia la tensione). |
| Phase chop Taglio di fase | Command that allows you to control the brightness variation by turning the dimmer clockwise or anticlockwise. (The input voltage varies). Comando che permette di controllare la variazione della luminosità ruotando il dimmer in senso orario o antiorario. (Varia la tensione di ingresso). |

| | |
|---|--|
|  | Indica che la fonte luminosa è a tecnologia LED. It indicates that the light source is LED |
| ON/OFF light bulb Lampadina ON/OFF | This symbol indicates that it is impossible to adjust the light intensity of the bulb. E' il simbolo che indica l'impossibilità di regolare l'intensità luminosa della lampadina |
| Dimmable light bulb Lampadina dimmerabile | This symbol indicates the possibility of adjusting the light intensity of the bulb. E' il simbolo che indica la possibilità di regolare l'intensità luminosa della lampadina. |
| UGR_L | The UGR is the unified index for the evaluation of direct glare from the lighting system. L'UGR è l'indice unificato per la valutazione dell'abbagliamento diretto derivante dall'impianto di illuminazione. |

SOCKET-PLUG PRESA-SPINA

SOCKET-PLUG PRESA-SPINA



Type C - EU 2 Poli CEE 7/16

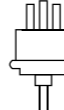

Type G - GRB 3 Poli

SUPPLY ALIMENTAZIONE

24V

220/240V

110/240V

Product Design
Quadrifoglio Group R&D Dept.

Project Direction & Coordination
Quadrifoglio Group Marketing & Communication Dept.

Creative Direction
Willy Dalto

Graphic Design
Federica Mattietto

Images
Nudesign, Udine

Color Separation & Print
Sincromia, Pordenone
January 2024 - Ed.01

Cod. LI0CLA22

Discover our Designers and Partners



